

Fronius IG Plus
3.0-1 / 3.8-1 / 5.0-1 / 6.0-1 / 7.5-1
10.0-1 / 11.4-1 / 11.4-3 / 12.0-3

USA Operating Instructions

Inverter for grid-connected photo-
voltaic systems



Dear Fronius Customer,

Introduction

Thank you for choosing Fronius - and congratulations on your new, high-quality, high-tech Fronius product. This introduction should provide you with general information about the equipment. Please read it carefully to learn about the many great features of your new Fronius product. This is the best way to get the most out of all the advantages that it has to offer.

Please also note the safety information and the safety precautions for the product installation location. Following all product instructions will ensure long-lasting quality and reliability. And these are the essential ingredients for outstanding results.



IMPORTANT SAFETY INSTRUCTIONS SAVE THESE INSTRUCTIONS

General

This manual contains important instructions for the Fronius IG Plus, that must be followed during installation and maintenance of the inverter.

The Fronius IG Plus is designed and tested according to international safety requirements, but as with all electrical and electronic equipment, certain precautions must be observed when installing and/or operating the Fronius IG Plus.

To reduce the risk of personal injury and to ensure the safe installation and operation of the Fronius IG Plus, you must carefully read and follow all instructions and safety instructions in this manual.

Safety Instructions

The following section “Safety Instructions” contains different Warnings. A Warning describes a hazard to equipment or personnel. It calls attention to a procedure or practice, which, if not correctly performed or adhered to, could result in damage to or destruction of part or all of the Fronius inverter and/or other equipment connected to the Fronius inverter or personal injury.

Electrical installations

All electrical installations must be made in accordance with the National Electrical Code, ANSI/NFPA 70, and any other codes and regulations applicable to the installation site.

For installations in Canada the installations must be done in accordance with applicable Canadian standards.

Safety Instructions

DANGER!



“**DANGER!**“ indicates an imminently hazardous situation which, if not avoided, will result in death or serious injury.

WARNING!



“**WARNING!**“ indicates a potentially hazardous situation which, if not avoided, will result in death or serious injury.

CAUTION!



“**CAUTION!**“ indicates a potentially harmful situation which, if not avoided, may result in minor and moderate injury or property damage.

NOTE



“**NOTE**“ indicates a situation which could adversely affect work results and may cause damage to equipment.

Important

“**Important**“ indicates practical tips and other useful information. It is not a signal word for a harmful or dangerous situation.

Please pay special attention when one of the above symbols appears in the manual.

General



This equipment has been manufactured using state-of-the-art technology and in accordance with general safety regulations. However, incorrect operation or misuse may endanger:

- the life and well-being of the operator or third parties
- the equipment and other property of the owner/operator
- the efficient operation of the equipment.

All persons involved with equipment startup, service and maintenance must:

- be suitably qualified
- be familiar with electrical installations
- have completely read and followed these operating instructions

The operating instructions must be available at the equipment location at all times. In addition to the operating instructions, all applicable local rules and regulations regarding accident prevention and environmental protection must also be followed.

General
(continued)

All safety instructions and warning signs on the equipment itself:

- must be maintained in legible condition
- must not be damaged
- must not be removed
- must not be covered or painted over

For information about where the safety instructions and warning signs are located on the equipment, please refer to the “General” section of your equipment’s operating instructions.

Any equipment malfunctions which might impair safety must be remedied immediately before the device is turned on.

Your safety is at stake.

Intended Use



The equipment may only be operated in compliance with its intended use.

Any other purpose does not constitute intended use. The manufacturer is not responsible for any damages resulting from unintended use.

Intended use also includes:

- reading and complying with all general information as well as safety information and warnings from the operating instructions
- compliance with all inspection and maintenance requirements
- installation as per operating instructions

Where appropriate, the following guidelines should also be applied:

- Utility company regulations regarding grid feed-in
- Information from solar module manufacturer

Ambient Conditions

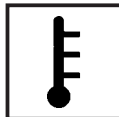

Operation and/or storage of the device outside of the stipulated range does not constitute intended use. The manufacturer is not responsible for any damages resulting from unintended use.

Please refer to the technical data in your operating instructions for information about permitted ambient conditions.

Qualified Personnel



The service information in these operating instructions is only intended for qualified personnel. An electrical shock can be fatal. Please do not carry out any activities other than those referred to in the documentation even if you are suitably qualified.



All cables and wires must be secured, undamaged, insulated and adequately dimensioned. Loose connections, scorched, damaged or under-dimensioned cables and wires must be repaired immediately by an authorized specialist.



Qualified Personnel
(continued)



Maintenance and repair may only be carried out by an authorized specialist.
The use of third-party parts does not guarantee that they were designed and manufactured according to operational demands and safety requirements. Use only original spare parts (also applies to standard parts).

Do not carry out any alterations, installations or modifications to the device without first obtaining the manufacturer's permission.

Immediately replace any components that are not in perfect condition.

Safety Precautions at Equipment Location

When installing devices with air vents, make sure that cool air can flow freely through the vents unobstructed. The device should only be operated in accordance with the protection class listed on the rating plate.

EMC Precautions



Care must be taken during installation to ensure that there is no electromagnetic interference with electrical and electronic equipment.

Electrical Installations



Electrical installations may only be carried out in accordance with relevant national and local standards and regulations.

ESD Precautions



Danger of damage to electronic components due to electrostatic discharge. Take appropriate ESD precautions when replacing and installing components.

Safety Precautions in Normal-Operation



The device should only be operated when all safety equipment is fully functional. If safety equipment is not fully functional, there is a danger to:

- the life and well-being of the operator or third parties
- the equipment and other property of the owner/operator
- the efficient operation of the equipment

Safety equipment that is not fully functional must be repaired by an authorized specialist before the device is turned on.

Never bypass or disable safety equipment.

Safety Markings



Equipment with the CE marking fulfils the basic requirements of the Guideline Governing Low-Voltage and Electromagnetic Compatibility. (For more information, please see the attachment and/or the “Technical Data“ section in your documentation).

Disposal



This device should not be disposed of in residential waste. To comply with European Directive 2002/96/EC on Waste Electrical and Electronic Equipment and its implementation as national law, electrical equipment that has reached the end of its life must be collected separately and returned to an approved recycling facility. Any device that you no longer require must be returned to your dealer or you must find an approved collection and recycling facility in your area. Ignoring this EU Directive may have adverse affects on the environment and your health.

Data Security

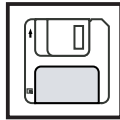

The user is responsible for backing up data relating to changes made to factory settings. The manufacturer will not accept liability if personal settings are deleted.

Copyright



The manufacturer maintains the copyright to these operating instructions.

Text and illustrations are technically correct at the time of going to print. The right to make modifications is reserved. The contents of the operating instructions shall not provide the basis for any claims whatsoever on the part of the purchaser. We would be grateful for any comments or suggestions regarding improvements and/or error corrections for the operating instructions.

Table of Contents

General Information	7
Protection of persons and equipment	9
Safety	9
Protection of persons and equipment	9
Galvanic isolation	9
Monitoring the grid	9
Information for Field adjustable trip points	10
FCC Compliance	10
Ground Fault Detector / Interruptor	10
Standards and Regulations	10
Product listings and compliance	10
The Fronius IG Plus Unit in the PV System	11
General information	11
Tasks	11
Converting DC into AC current	11
Fully automatic operation management	11
Display function and data communication	12
System Upgrades	12
Forced ventilation	12
Power Derating	13
Installation and Startup	15
Fronius IG Plus Installation and Connection	17
Safety	17
Fronius IG Plus Construction	17
Connection Diagramm	18
Overview	18
Fronius IG Plus Connection Options	19
Fronius IG Plus Connection Options	19
Knockouts on the Fronius IG Plus	21
General	21
Knockouts for Wire Inputs	21
Choosing the Location	23
Choosing the location general	23
Choosing a Location for Inside Installation	23
Choosing a Location for Outside Installation	24
Fronius IG Plus Installation	25
General	25
Assembling the Wall Bracket	25
Recommended Screws for Wall Bracket Assembly	25
Attaching the Wall Bracket - Mounting height	25
Attaching the Wall Bracket to a Concrete or Brick Wall	26
Attaching the Wall Bracket to a Wooden Wall	26
Attaching the Wall Bracket to a Metal Carrier	27
Fronius IG Plus Installation	27
Installation of Several Inverters	28

Connecting the Fronius IG Plus to the Public Grid (AC)	29
Overview of Available Power Grids	29
Monitoring the Grid	31
Schemes with more than one inverter	31
AC-side and Grounding Terminals	32
Cross Section of AC Wires	33
Safety	33
Connecting the Fronius IG Plus to the Public Grid (AC)	34
Connecting Grounding Electrode Wire	35
Recommendation for the AC-side over current protection	35
Additional External AC and/or DC Disconnect	35
Connecting Solar Module Strings to the Fronius IG Plus (DC)	36
General Information About Solar Modules	36
Safety	36
DC-Terminals	37
Overview	37
Connecting Solar Module Strings	38
Solar Module Ground	38
Wire Cross Section of Solar Module Strings	38
Connecting Solar Module Strings	39
Inserting String fuses into the Fronius IG Plus	41
Criteria for the Proper Selection of String Fuses	42
DC disconnect requirements	42
General	42
Criteria for the Proper Selection of String Fuses	42
Effects of using underrated fuses	42
Fuse Recommendations - Application Example	43
Fuses	43
Additional Required Components	44
Solar Module Ground	44
Connecting combined Solar Module Strings using a DC String Input Combiner	44
General	44
Connecting combined Solar Module Strings using a DC String Input Combiner	45
Safety	45
Solar Module Ground at Positive Pole: Connecting Solar Module Strings	48
General	48
Wire Cross Section of Solar Module Strings	48
Solar Module Ground at Positive Pole	48
Solar Module Ground at Positive Pole: Connecting Solar Module Strings	49
Solar Module Ground at Positive Pole: Inserting String fuses into the Fronius IG Plus	51
Criteria for the Proper Selection of String Fuses	53
DC disconnect requirements	53
General	53
Criteria for the Proper Selection of String Fuses	53
Effects of using underrated fuses	53
Fuse Recommendations - Application Example	54
Fuses	54

Solar Module Ground at Positive Pole: Connecting combined Solar Module Strings using a DC String Input Combiner	55
General	55
Additional Required Components	55
Solar Module Ground at Positive Pole	55
Solar Module Ground at Positive Pole: Connecting combined Solar Module Strings using a DC String Input Combiner	56
Safety	56
Attaching Power Stage Sets and Closing the Fronius IG Plus	59
Preparation	59
Opening the Fronius IG Plus for Service/Maintenance	59
Attaching Power Stage Sets And Closing the Fronius IG Plus	59
Start up Operation	60
Factory pre-set configuration	60
Requirements for Starting up Operation	60
Start up Operation	60
Selecting the public grid	61
Startup Phase at Startup Operation	63
Inserting Option Cards	65
Suitable Option Cards	65
Safety	65
Opening the Fronius IG Plus	65
Inserting Option Cards	66
Connecting Option Cards, Laying Data Communication Wires	66
Solar Net and Data Interface	68
Closing the Fronius IG Plus	68
Example	69

Operation 71

Product description Fronius IG Plus	73
Keys and Symbols	73
Display	73
Test Procedure	75
Startup phase	75
Operating Status LED	77
Operating scheme - the Display	79
Activating	79
Display Illumination	79
Accessing Menus	79
Selecting a display mode	80
Scrolling Between Display functions	80
Overview of Display Values	81
Display Modes	82
Display Modes	82
Overview	82
Within display mode 'Now' displayed data	83
Selecting display mode 'Now'	83
Within display mode 'Now' displayed data	83
Options	85

Within display modes 'Day / Year / Total' displayed data	86
General	86
Selecting display modes 'Day / Year / Total'	86
Within display modes 'Day / Year / Total' displayed data	87
Options	89
The Setup Menu	90
Default Settings	90
Enter the setup menu	90
Scrolling among menu items	91
Menu Items in the Setup Menu	91
Setting and Displaying Menu Items	94
Menu Items Settings - General	94
Setting Menu Item 'Standby'	94
Setting menu item 'CONTRast'	95
Setting menu item 'LIGHTmode'	95
Setting menu item 'CASH'	96
Setting menu item 'CO2'	98
Setting menu item 'YIELD'	99
Setting menu item 'IG-NR'	102
Setting menu item 'DATcom'	103
Setting menu item 'TIME'	104
Displaying menu item 'STATEps'	107
Displaying menu item 'VERSlon'	108

Troubleshooting and Maintenance 113

Status Diagnosis and Troubleshooting	115
Displaying Status Codes	115
Normal operation status codes	115
Total failure	115
Status Codes on Fronius IG Plus with several power stage sets	116
Class 1 Status Codes	116
Class 2 Status Codes	118
Class 3 Status Codes	119
Class 4 Status Codes	121
Class 5 Status Codes	128
Customer Service	130
Maintenance	131
Safety	131
General	131
Operation in Dusty Environments	132
Opening Fronius IG Plus for Service/Maintenance	132
Replacing String Fuses	133
Safety	133
Preparation	133
Replacing String Fuses	134
Closing Fronius IG Plus	135
Replacing GFDI Fuse	136
Safety	136
Preparation	136
Replacing GFDI Fuse	137
Closing Fronius IG Plus	138

Technical Data 141

- Fronius IG Plus 3.0-1 141
- Fronius IG Plus 3.8-1 143
- Fronius IG Plus 5.0-1 145
- Fronius IG Plus 6.0-1 147
- Fronius IG Plus 7.5-1 149
- Fronius IG Plus 10.0-1 151
- Fronius IG Plus 11.4-1 153
- Fronius IG Plus 11.4-3 155
- Fronius IG Plus 12.0-3 157
- Field adjustable trip points 159

Relevant Standards and Directives 160

- Relevant Standards and Directives 160
- Grid Failure 160

Warranty and Disposal 161

- FRONIUS USA limited 10-Year Warranty 161
- Policy and procedure for warranty returns and repairs 161
- Disposal of obsolete equipment - Recycling 162

General Information

Protection of persons and equipment

Safety



WARNING! An electrical shock can be fatal. Danger from grid voltage and DC voltage from solar modules.

- The connection area should only be opened by a licensed electrician.
- The separate power stage set area should only be disconnected from the connection area after first being disconnected from the grid power.
- The separate power stage set area should only be opened by Fronius-trained service personnel.

Never work with live wires! Prior to all connection work, make sure that the AC and DC wires are not charged.



WARNING! Incorrect operation and work performed incorrectly can cause serious injury & damage! Only qualified staff are authorized to install your Fronius IG Plus and only within the scope of the respective technical regulations. Do not start operation or carry out maintenance work before you have read the chapter 'Safety Instructions'!

Protection of persons and equipment

The design and function of the Fronius IG Plus unit offers a maximum level of safety, both during installation as well as in operation.

The Fronius IG Plus provides operator and equipment protection through:

- a) galvanic isolation
- b) monitoring the grid

Galvanic isolation

The Fronius IG Plus is equipped with a high frequency transformer that ensures galvanic isolation between the DC side and the grid, thus ensuring the highest possible safety.

Monitoring the grid

Whenever conditions in the electric grid are inconsistent with standard conditions (for example grid switch-off, interruption, etc.), your Fronius IG Plus unit will immediately stop operating and interrupt the supply of power into the grid.

Monitoring the grid
(continued)

Your Fronius IG Plus unit determines the grid's status by:

- monitoring voltage
- monitoring frequency
- monitoring islanding conditions

Information for Field adjustable trip points

The Fronius IG Plus unit is provided with field adjustable trip points. For further information please contact Fronius technical support E-Mail: pv-us-support@fronius.com.

FCC Compliance



This device complies with Part 15 of the FCC Rules. Operation is subject to the following conditions:
(1) This device may not cause harmful interference, and
(2) this device must accept any interference received, including interference that may cause undesired operation.

Ground Fault Detector / Interruptor

The Fronius IG Plus is equipped with a ground fault detection and interruption (GFDI) circuit as required by UL 1741 and the National Electrical code.

Depending on the system configuration either the PV array's negative or positive conductor is connected to the grounding system in the inverter. If a ground fault occurs in the DC wiring, the inverter disconnects from the grid.

Standards and Regulations

Your Fronius IG Plus unit complies with the requirements for the following standards "Inverters, converters and controllers for use in independent power systems":

- UL1741-2005
- IEEE 1547-2003
- IEEE 1547.1
- ANSI / IEEE C62.41
- C22.2 No. 107.1-01 (Sep. 2001)

The ground-fault detection and interruption is in compliance with NEC 690 building code requirements.

Product listings and compliance

The respective conformity declarations can be found in the appendix to these operating instructions.

The Fronius IG Plus Unit in the PV System

General information

The solar inverter Fronius IG Plus is the highly complex link between solar modules and the grid.

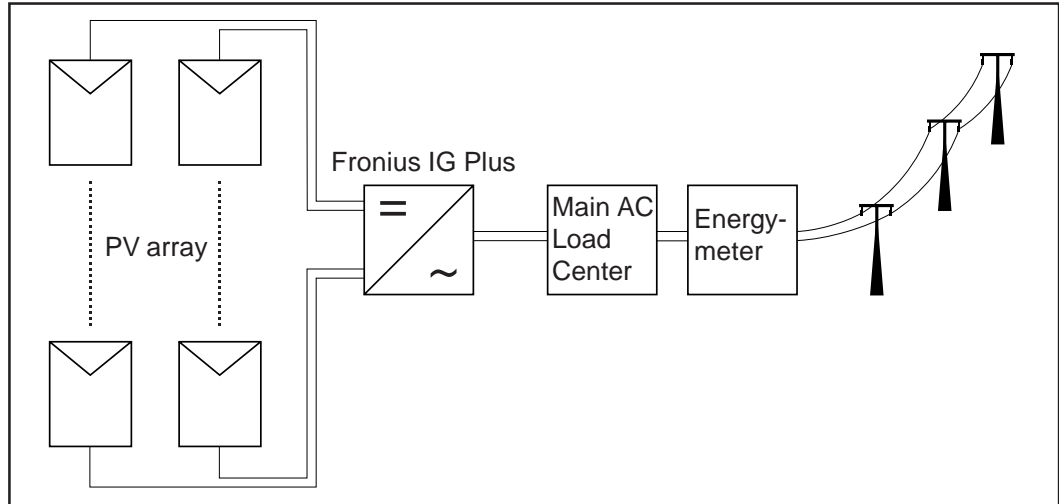

Tasks

The main tasks of the Fronius IG Plus include:

- Converting DC into AC current
- Fully automatic operation management
- Display function and data communication

Converting DC into AC current

The Fronius IG Plus unit transforms the direct current generated by the solar modules into alternating current. This alternating current is fed into your home system or into the public grid and synchronized with the voltage that is used there.

Important The Fronius IG Plus has been designed exclusively for use in grid connected photovoltaic systems. It cannot generate electric power independent from the grid.

Fully automatic operation management

The Fronius IG Plus is fully automatic. Starting at sunrise, as soon as the solar modules generate enough power, the automatic control unit starts monitoring voltage and frequency. As soon as there is a sufficient level of irradiance, your solar inverter starts feeding energy to the grid.

The control system of the Fronius IG Plus unit ensures that the maximum possible power output is drawn from the solar modules at all times. This function is called MPPT (Maximum Power Point Tracking).

Fully automatic operation management
(continued)

As dusk starts and there is no longer sufficient energy available to feed power into the grid, the Fronius IG Plus unit shuts down the grid connection completely and stops operating. All settings and data recorded are saved.

Display function and data communication

The display on the inverter is the interface between the inverter and the operator. The design of the display is geared towards simple operation and making system data available as long as the inverter operates.

The Fronius IG Plus is equipped with a basic logging function to monitor minimum and maximum data on a daily and a cumulative basis. These values are shown on the display.

There is also an option to allow the reading of the following weather data on the display:

- two different temperature readings (for example, temperature at the solar modules as well as the outside temperature)
- irradiance

A wide choice of data communication products allows for many possibilities of recording and viewing data.

System Upgrades

The Fronius IG Plus is designed for various system upgrades, e.g.:

- Upgrades that enable Fronius IG Plus to communicate with external system upgrades as well as other inverters
- Datalogger and modem interface, Ethernet/Internet connection (for using a PC to record and manage data from your photovoltaic system)
- Various large-format displays
- Living room display (Fronius Personal Display)
- Sensors (e.g. for temperature, irradiance, energy meter, wind speed)
- Interface cards

System upgrades are available as plug-in cards or external boxes.

Forced ventilation

The temperature controlled, variable speed fan with ball bearing support of the Fronius IG Plus provides:

- optimal inverter cooling
- efficiency increases
- cooler components, thus improving service life
- least possible energy consumption and noise level

Power Derating

Should there be insufficient heat dissipation in spite of the fan operating at maximum speed (for example inadequate heat transfer away from the heat sinks) the power will be derated for protection of the Fronius IG Plus unit.

Derating the power reduces the output of the Fronius IG Plus unit for a short period sufficient to ensure that the temperature will not exceed the admissible limit.

Your Fronius IG Plus unit will remain ready for operation as long as possible without any interruption.

Installation and Startup

Fronius IG Plus Installation and Connection

Safety



WARNING! An electrical shock can be fatal. Danger from grid voltage and DC voltage from solar modules.

- The connection area should only be opened by a licensed electrician.
- The separate power stage set area should only be disconnected from the connection area after first being disconnected from the grid power.
- The separate power stage set area should only be opened by Fronius-trained service personnel.

Never work with live wires! Prior to all connection work, make sure that the AC and DC wires are not charged.



WARNING! Incorrect operation and work performed incorrectly can cause serious injury & damage! Only qualified staff are authorized to install your Fronius IG Plus and only within the scope of the respective technical regulations. Do not start operation or carry out maintenance work before you have read the chapter 'Safety Instructions'!

Fronius IG Plus Construction

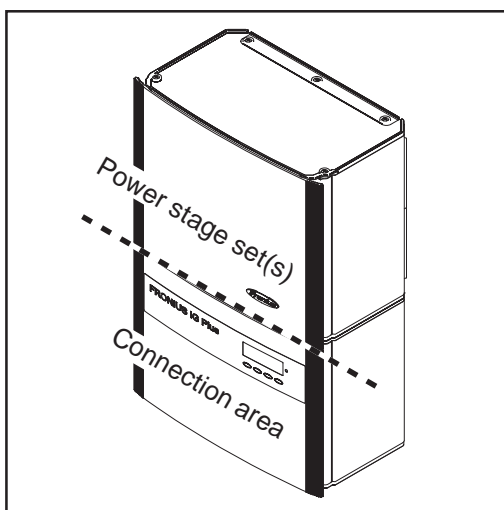

Connection area and power stage set on the Fronius IG Plus

The power stage set and the connection area are separated from each other for delivery.

Connection Diagramm

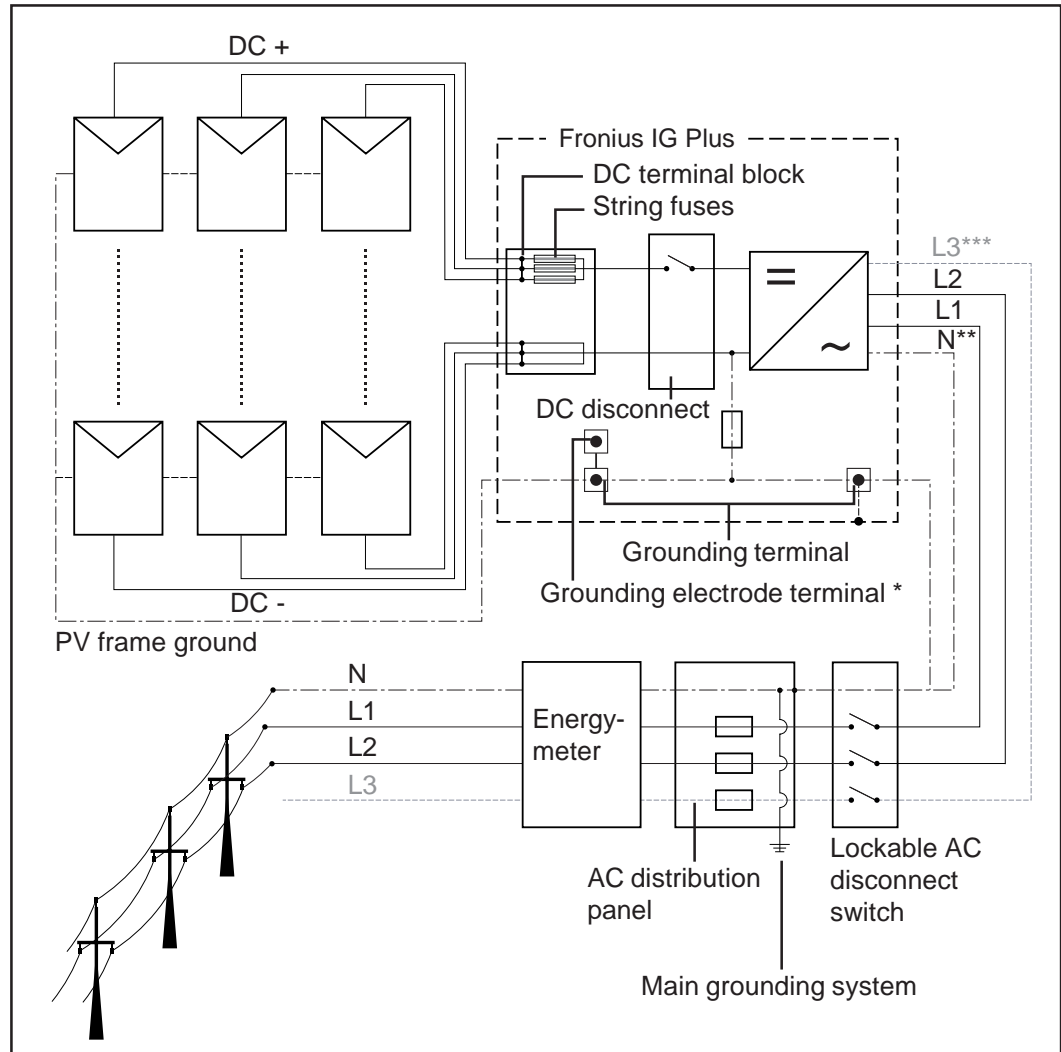

* may be required by local authorities

** may be required depending on grid configuration

*** depending on inverter type

Overview

'Fronius IG Plus Installation and Connection' contains the following sections:

- Fronius IG Plus Connection Options
- Knockouts on the Fronius IG Plus
- Choosing the Location
- Fronius IG Plus Installation
- Connecting the Fronius IG Plus to the Public Grid (AC)
- Connecting Solar Module Strings to the Fronius IG Plus (DC)
- Attaching Power Stage Sets and Closing the Fronius IG Plus

Fronius IG Plus Connection Options

Fronius IG Plus Connection Options

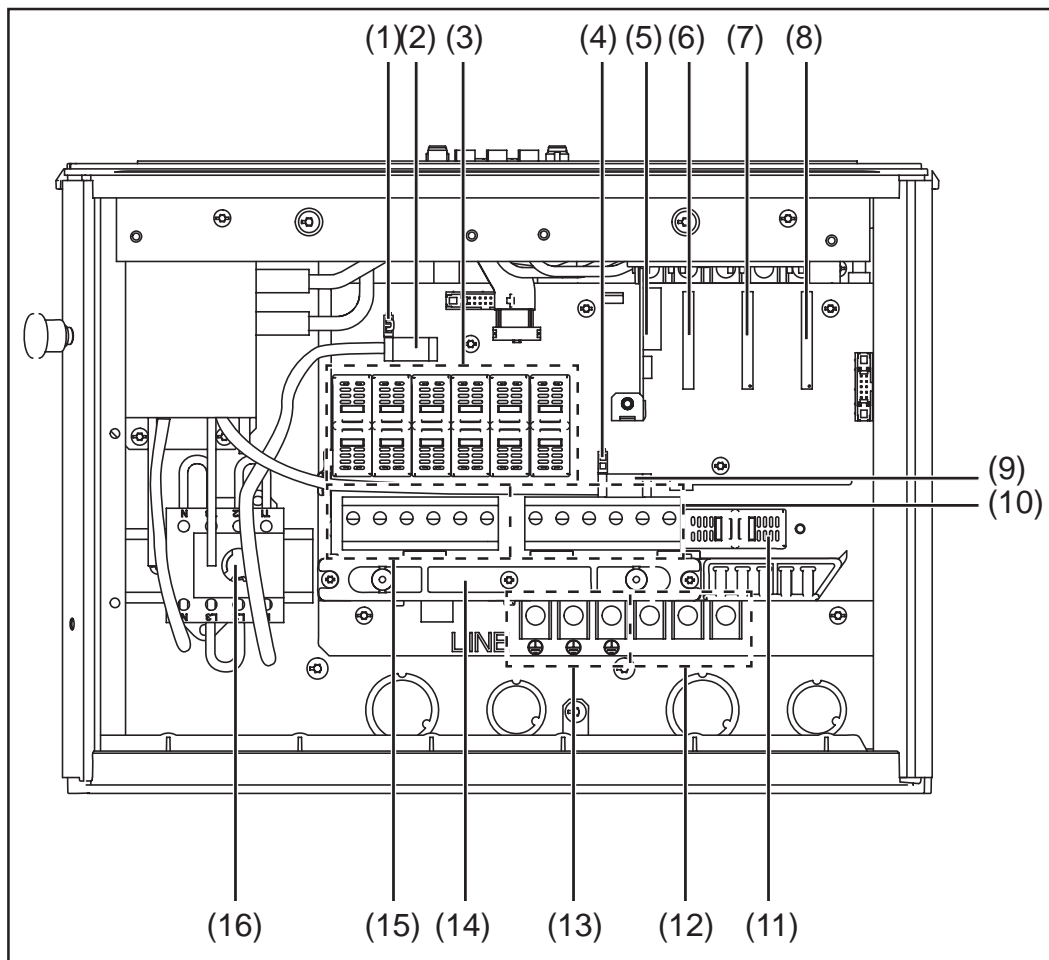

Connections on the Fronius IG Plus

Item	Description
(1)	Jumper slot SM _{ON}
(2)	DC+ main switch wire
(3)	6 x fuse holder with fuse cover, for stringfuses
(4)	Jumper slot SM _{OFF}
(5)	Plug-in card IG Brain
(6)	Open card slot for an option card
(7)	Open card slot for an option card
(8)	Plug-in card NL-MON Only at Fronius IG Plus 12.0-3 WYE 277: Open card slot for an option card
(9)	DC- main switch wire
(10)	6 DC- terminals
(11)	fuse holder with fuse cover, for GFDI-fuse

**Fronius IG
Plus Connection Options**
(continued)

Item	Description
(12)	AC-side terminals
(13)	3 x grounding terminals
(14)	Strain relief for solar module strings
(15)	6 DC+ terminals
(16)	DC main switch

Knockouts on the Fronius IG Plus

General

The Fronius IG Plus contains several knockouts of different sizes. When knocked out, the openings are used for the inputs of various wires.

Knockouts for Wire Inputs

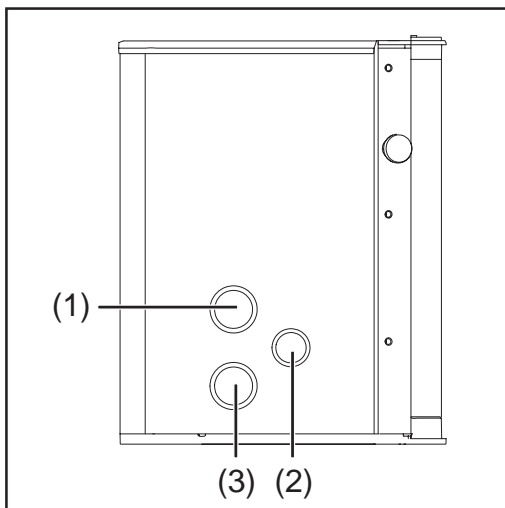

Knockouts on the lefthand side

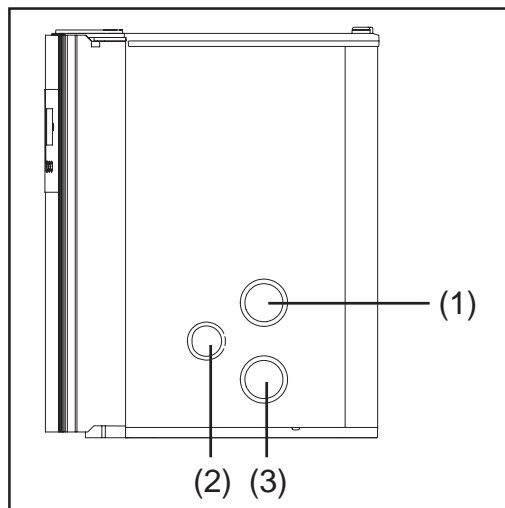

Knockouts on the righthand side

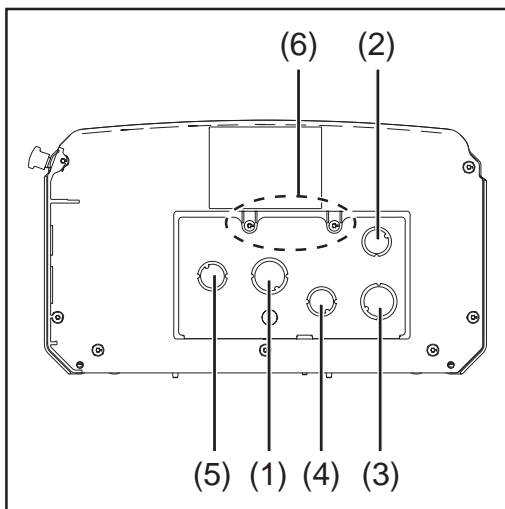

Knockouts on the underside

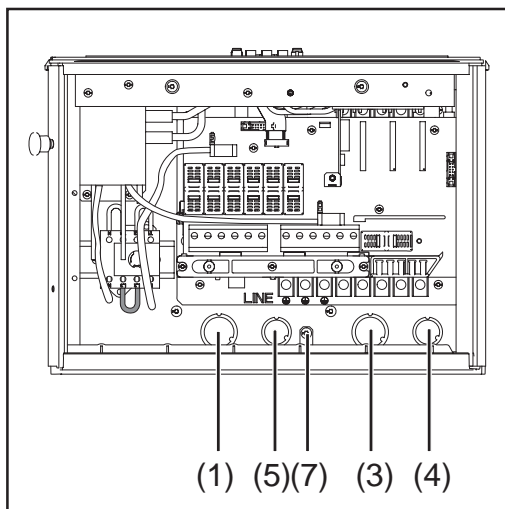

Knockouts on the backside

Item	Description
(1)	Knockout, diameter 3/4 in. / 1 in. e.g. for DC wire, surge arrester
(2)	Knockout, diameter 1/2 in. / 3/4 in. only for data wires
(3)	Knockout, diameter 3/4 in. / 1 in. e.g. for AC wire, surge arrester
(4)	Knockout, diameter 1/2 in. / 3/4 in. e.g. for AC wire, surge arrester

Knockouts for Wire Inputs
(continued)

Item	Description
(5)	Knockout, diameter 1/2 in. / 3/4 in. e.g. for DC wire, surge arrester
(6)	FTX 25 fixing screws
(7)	FTX 25 fixing screw



NOTE When using back wire inputs:
- seal on enclosure NEMA 3R before outside operation



NOTE

- The larger knockouts should only be removed from the outside in.
- The smaller knockouts should be removed from the inside out.
- Only remove the number of knockouts required for the available wire inputs



CAUTION! Danger of damaging the plastic base when removing the knockouts on the bottom.

- Before removing, remove the 3 fixing screws (6) and (7)
- Remove the metal insert from the plastic base
- Remove the required knockouts
- Replace the metal insert into the plastic base
- Secure the metal insert using the 3 fixing screws (6) and (7)

Choosing the Location

Choosing the location general

Please note the following criteria when choosing a location for the Fronius IG Plus:

Only vertical installation

Max. ambient temperatures: -4 °F / +122 °F (-20 °C / +50 °C)

Keep a distance of 8 in. (20 cm) minimum between each inverter or anything to the right or left of the inverters such as walls or DC and AC disconnects.

For optimal airflow and cooling efficiency in hot climates Fronius recommend a distance of 10 - 12 in. (25 - 30 cm).

When installing more than one unit, keep a distance of 12 in. (30 cm) between each Fronius IG Plus.

Keep a clearance of 3 ft. (66 cm) minimum below the unit, according to NEC for code compliant disconnect location

The air flow direction within the inverter is from right to left (cold air intake on right, hot air exit on left).

When installing the Fronius IG Plus unit in a switch panel cabinet (or similar closed environment) it is necessary to make sure that the hot air that develops will be discharged by forced ventilation.

The Fronius IG Plus is designed for installation both indoors and outdoors.

Choosing a Location for Inside Installation

During certain operation phases the Fronius IG Plus unit may produce a slight noise. For this reason it should not be installed in an occupied living area.

Do not install the Fronius IG Plus in:

- areas with large amounts of dust
 - areas with large amount of conducting dust particles (e.g. iron filings)
 - areas with corrosive gases, acids or salts
 - areas where there is an increased risk of accidents, e.g. from farm animals (horses, cattle, sheep, pigs, etc.)
 - Stables or adjoining areas
 - Storage areas for hay, straw, chaff, animal feed, fertilizers, etc.
 - Storage or processing areas for fruit, vegetables or winegrowing products
 - Rooms used in the preparation of grain, green fodder or animal feeds
 - Greenhouses
-

**Choosing a
Location for
Outside Instal-
lation**

NEMA 3R protection means that the Fronius IG Plus can be exposed to moisture. However, we recommend that direct moisture and direct water spray such as a sprinkler be avoided, if possible.

In order to protect the display, the Fronius IG Plus should not be exposed to direct sunlight. Ideally, the Fronius IG Plus should be installed in a protected location, e.g. near the solar modules or under a roof overhang.

Fronius IG Plus Installation

General

Important Depending on the surface, different dowels and screws may be required for installing the wall bracket. These dowels and screws are not part of the scope of delivery for the Fronius IG Plus. The installer is responsible for selecting the proper dowels and screws.



NOTE The Fronius IG Plus should only be installed upright on the wall.

Assembling the Wall Bracket

Only for Fronius IG Plus 10.0-1 / 11.4-1 / 11.4-3 / 12.0-3:

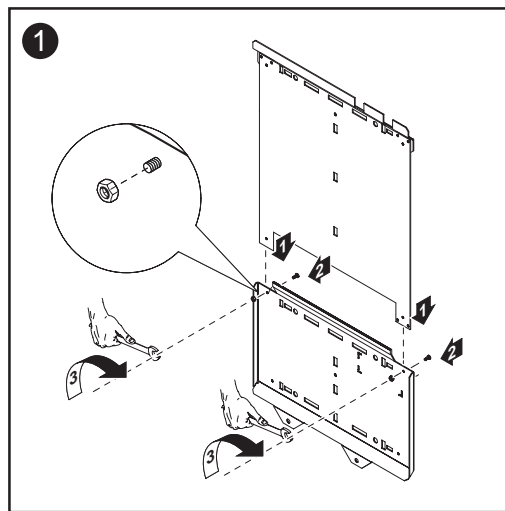

Because of logistical limits, the wall bracket for these inverters is divided into two parts.

- Assemble wall bracket as per step 1

Recommended Screws for Wall Bracket Assembly

In most cases, you should use 1/4 in. or 5/16 in. stainless steel or aluminum screws capable of supporting 31 lbs. (Fronius IG Plus 3.0-1 / 3.8-1), 57 lbs. (Fronius IG Plus 5.0-1 / 6.0-1 / 7.5-1), or 82 lbs. (Fronius IG Plus 10.0-1 / 11.4-1 / 11.4-3 / 12.0-3) of inverter weight.

Attaching the Wall Bracket - Mounting height

Important NEC requires that the DC disconnect be mounted between 3 ft. and 6 1/2 ft. from the ground if it is to be used as a code-compliant disconnect.

The DC disconnect is in the lower left part of the inverter. Also, the cut out segment marked (*) in the following drawings represents the placement of the inverter display. Use this to ensure a comfortable display height for easy reading.

Attaching the Wall Bracket to a Concrete or Brick Wall

Important The cut out segment marked (*) represents the placement of the inverter display. Use this to ensure a comfortable display height for easy reading.

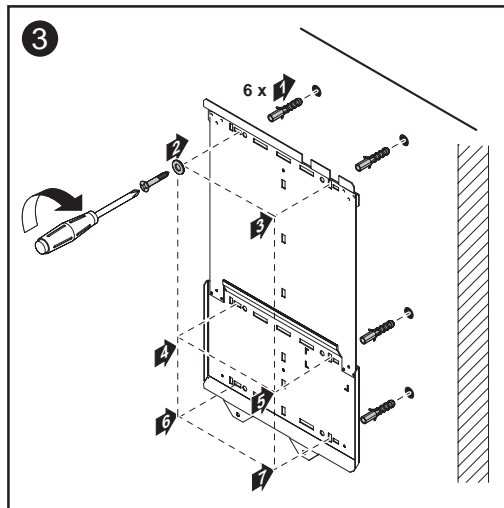
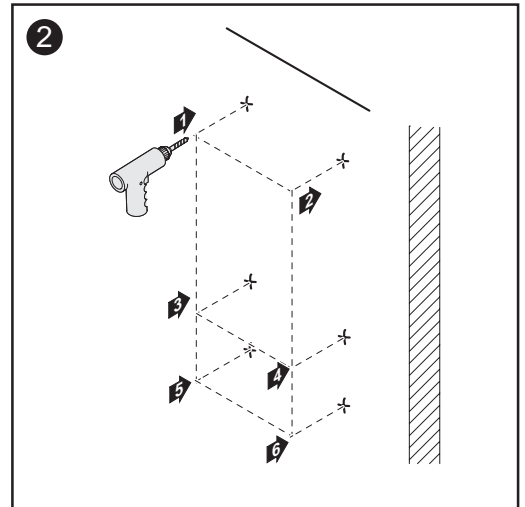
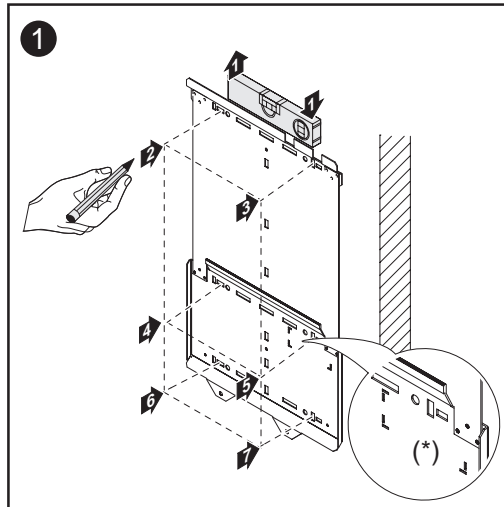

Attaching the Wall Bracket to a Wooden Wall

Important The cut out segment marked (*) represents the placement of the inverter display. Use this to ensure a comfortable display height for easy reading.

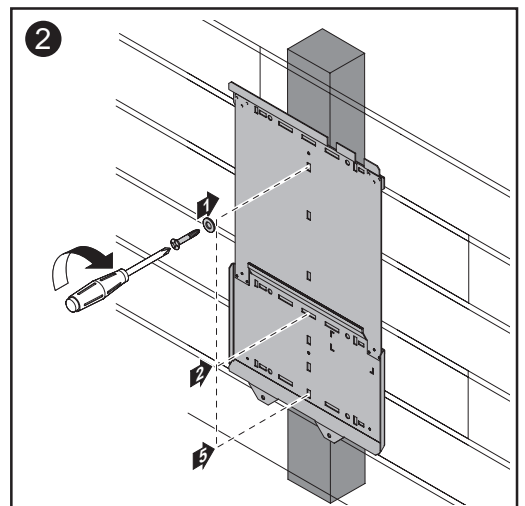
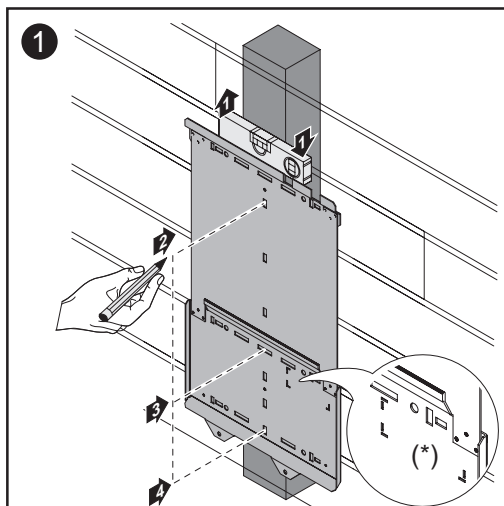

Attaching the Wall Bracket to a Metal Carrier

Important The cut out segment marked (*) represents the placement of the inverter display. Use this to ensure a comfortable display height for easy reading.

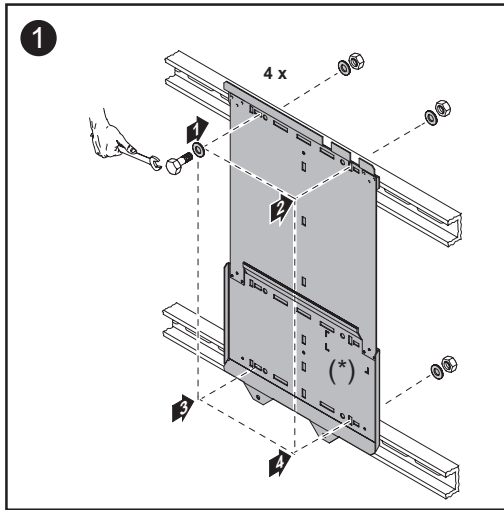

NOTE When installing using a metal carrier, the Fronius IG Plus should not be exposed to rainwater or water spray at the back. Ensure proper rainwater or spray water protection.

Fronius IG Plus Installation

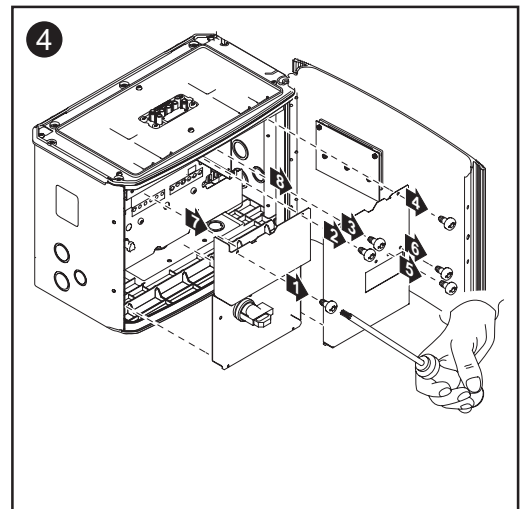
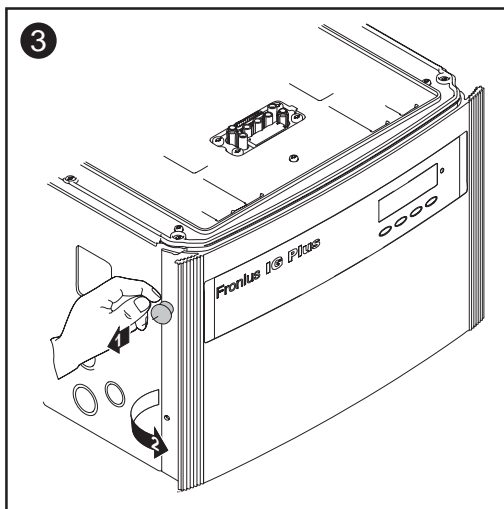
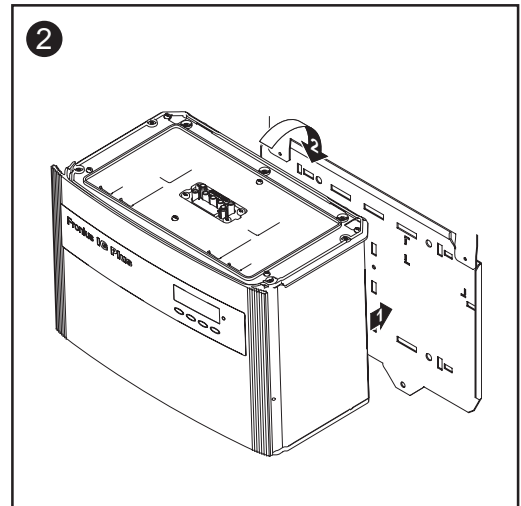
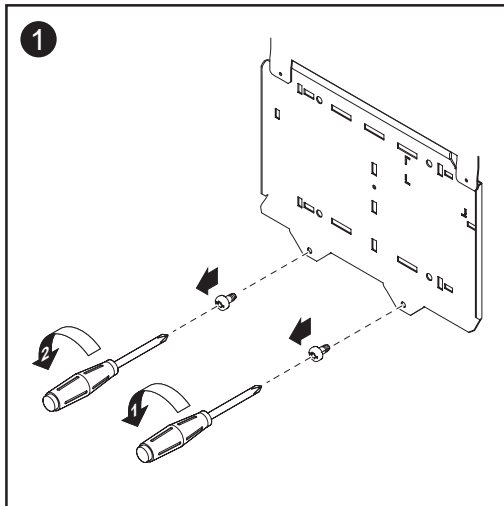

Fronius IG Plus Installation
(continued)

CAUTION! Danger of injury by falling equipment. Attach the connection area of the inverter to the wall bracket using the 2 screws removed from the wall bracket in step 1.

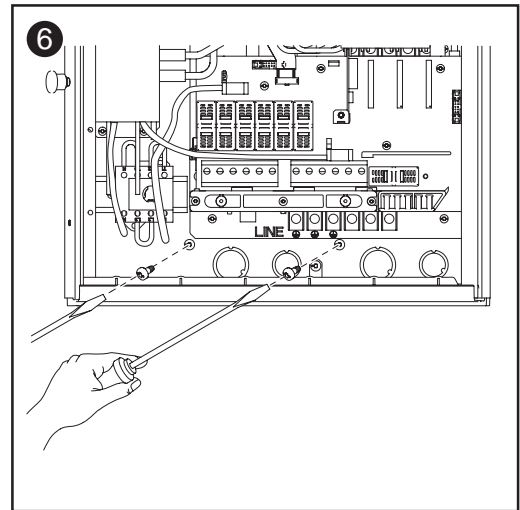
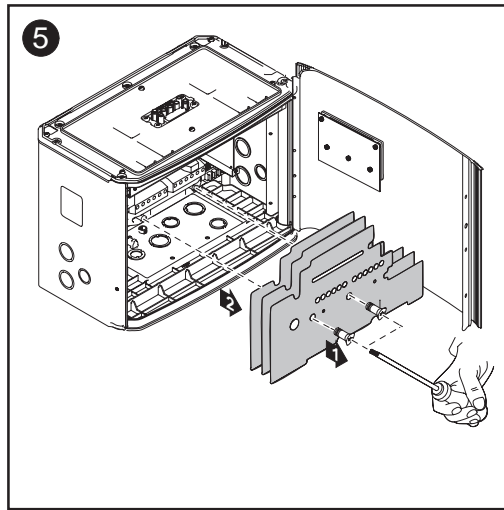

Installation of Several Inverters

Several inverters can be easily installed and connected next to each other using the side knockouts on the Fronius IG Plus, e.g.:

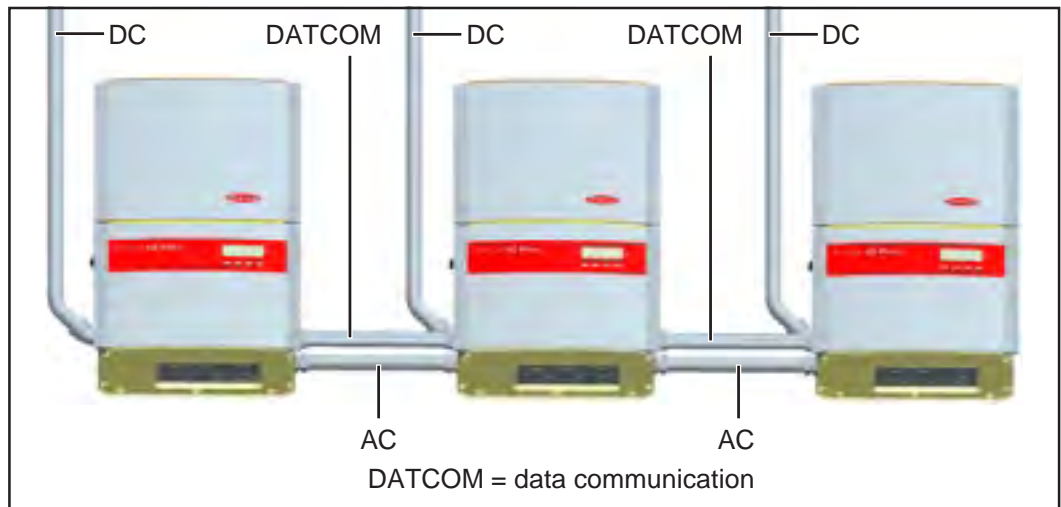

NOTE All electrical installations must be made in accordance with the National Electrical Code, ANSI/NFPA 70, and any other codes and regulations applicable to the installation site.

For installations in Canada the installations must be done in accordance with applicable Canadian standards.

Connecting the Fronius IG Plus to the Public Grid (AC)

Overview of Available Power Grids

Fronius IG Plus inverters can be connected to the following power grids:

Public Grid

Inverter

208 V Delta

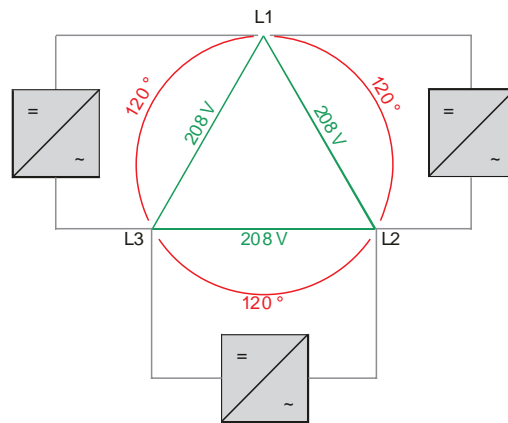

- Fronius IG Plus 3.0-1
- Fronius IG Plus 3.8-1
- Fronius IG Plus 5.0-1
- Fronius IG Plus 6.0-1
- Fronius IG Plus 7.5-1
- Fronius IG Plus 10.0-1
- Fronius IG Plus 11.4-1
- Fronius IG Plus 11.4-3

208 V Delta: 120 V WYE

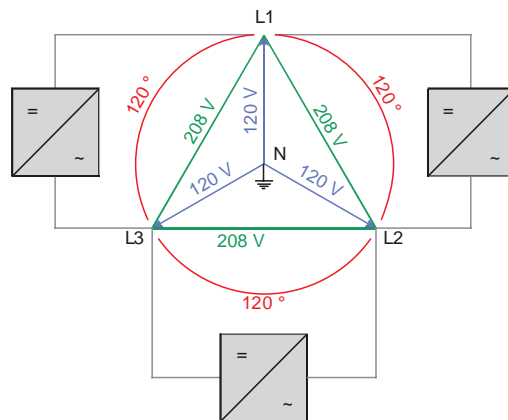

- Fronius IG Plus 3.0-1
- Fronius IG Plus 3.8-1
- Fronius IG Plus 5.0-1
- Fronius IG Plus 6.0-1
- Fronius IG Plus 7.5-1
- Fronius IG Plus 10.0-1
- Fronius IG Plus 11.4-1
- Fronius IG Plus 11.4-3

240 V Delta

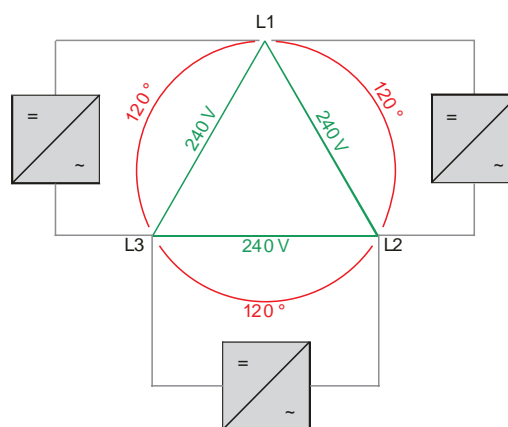

- Fronius IG Plus 3.0-1
- Fronius IG Plus 3.8-1
- Fronius IG Plus 5.0-1
- Fronius IG Plus 6.0-1
- Fronius IG Plus 7.5-1
- Fronius IG Plus 10.0-1
- Fronius IG Plus 11.4-1
- Fronius IG Plus 11.4-3

Overview of Available Power Grids
(continued)

Public Grid

240 V: 120 V Stinger

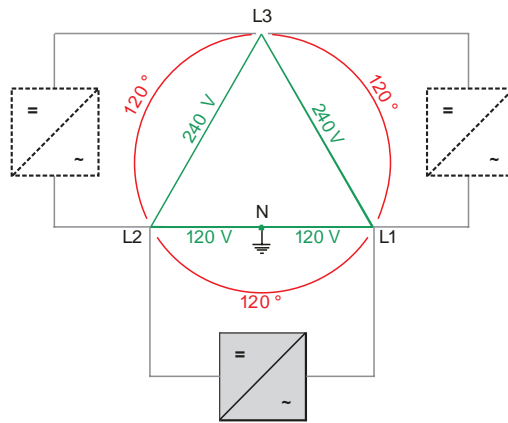

Inverter

- Fronius IG Plus 3.0-1
- Fronius IG Plus 3.8-1
- Fronius IG Plus 5.0-1
- Fronius IG Plus 6.0-1
- Fronius IG Plus 7.5-1
- Fronius IG Plus 10.0-1
- Fronius IG Plus 11.4-1

240 V: 120 V Split phase

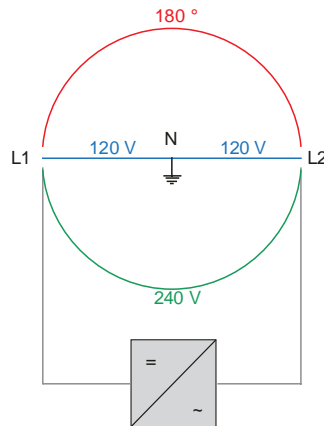

- Fronius IG Plus 3.0-1
- Fronius IG Plus 3.8-1
- Fronius IG Plus 5.0-1
- Fronius IG Plus 6.0-1
- Fronius IG Plus 7.5-1
- Fronius IG Plus 10.0-1
- Fronius IG Plus 11.4-1

480 V Delta: 277 V WYE

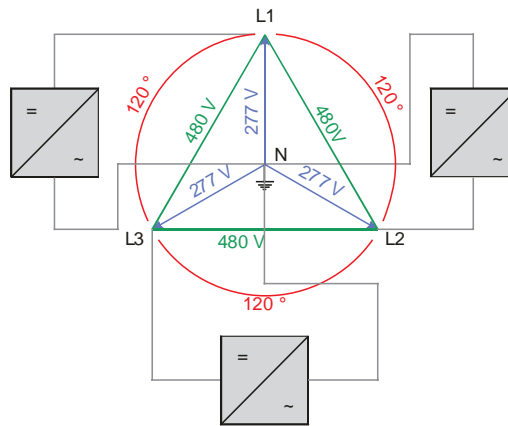

- Fronius IG Plus 3.0-1
- Fronius IG Plus 3.8-1
- Fronius IG Plus 5.0-1
- Fronius IG Plus 6.0-1
- Fronius IG Plus 7.5-1
- Fronius IG Plus 10.0-1
- Fronius IG Plus 11.4-1

Fronius IG Plus 12.0-3

Overview of Available Power Grids (continued)

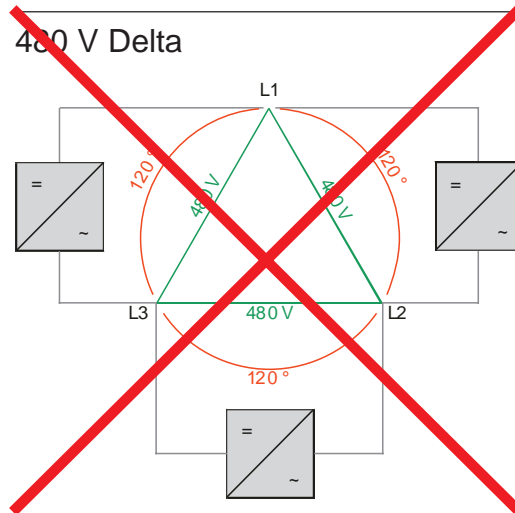

NOTE Do not connect Fronius IG Plus inverters to the 480 V Delta power grid.

Monitoring the Grid



NOTE For optimal functioning of grid monitoring the resistance in the leads to the AC side connection terminals must be as low as possible. The AC conductor resistance between the Fronius IG Plus unit and the building's distribution panel should not exceed 0.5 Ohm.

Schemes with more than one inverter

For larger photovoltaic schemes it is possible to connect several Fronius IG Plus units in parallel without any problems. To ensure symmetrical feeding, connect the inverters uniformly to all phases.



NOTE The Fronius IG Plus is designed to be connected to three phase systems. Utilities generally allow up to 6 kVA of unbalance but check with your utility and try to balance the installation. The connection to the grid shall be done in the following way:

208 V / 240 V:

- Connect Fronius IG Plus No. 1, No. 4, No. 7, ... to L1 and L2
- Connect Fronius IG Plus No. 2, No. 5, No. 8, ... to L2 and L3
- Connect Fronius IG Plus No. 3, No. 6, No. 9, ... to L1 and L3

277 V:

- Connect Fronius IG Plus No. 1, No. 4, No. 7, ... to L1 and N
- Connect Fronius IG Plus No. 2, No. 5, No. 8, ... to L2 and N
- Connect Fronius IG Plus No. 3, No. 6, No. 9, ... to L3 and N

AC-side and Grounding Terminals

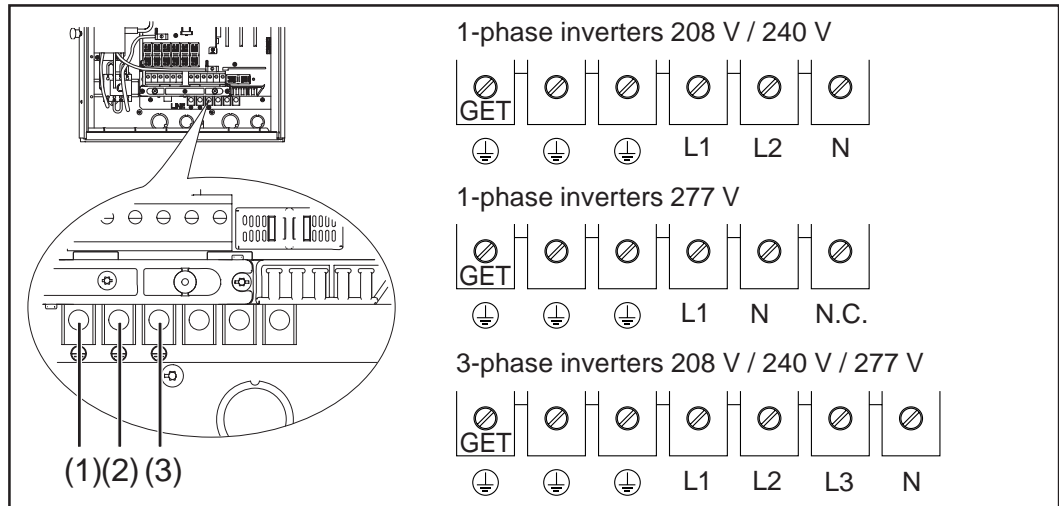

AC-side and Grounding Terminals

The terminals are designed for the following terminal connections:

Grounding Terminals:

(1) Grounding Electrode Terminal (GET)

A grounding electrode conductor may be required by the Authority Having Jurisdiction (AHJ).

(2) Equipment grounding (e.g. grounding of the solar module frame)

The PV array (frame) ground should be connected to the Grounding Terminal. The size for the conductor is usually based on the size of the largest conductor in the DC system.

(3) Grid grounding / Grounding conductor

The Fronius IG Plus Inverter must be connected to the AC ground from the utility via the Ground Terminal.

NOTE

- Use copper wire for all grounding wires.
- Use only solid or stranded wire. Do not use fine stranded wire.
- For appropriate grounding see NEC Section 250.

AC-side Terminals:

L1 = Phase conductor L1

L2 = Phase conductor L2

L3 = Phase conductor L3

N = Neutral conductor N

NOTE

The neutral conductor is not bonded to ground internally.

N.C. = Not connected

max. wire cross section AWG 4

Cross Section of AC Wires



WARNING! An electric shock can be fatal. Inadequately sized electrical components can cause serious injuries to persons and damage to (or loss of) property.

- All electrical installations must be in accordance with the National Electrical Code, ANSI/NFPA 70, and any other codes and regulations applicable to the installation site.
- For installations in Canada the installations must be done in accordance with applicable Canadian standards.
- Use minimum AWG 14 to maximum AWG 4, min. 167°F (75°C), copper wire for all AC wiring connections to the Fronius IG Plus. Voltage drop and other considerations may dictate larger size wires be used.
- Use only solid or stranded wire. Do not use fine stranded wire.

Fronius IG Plus	AC wire 208 V	AC wire 240 V	AC wire 277 V
3.0-1	AWG 12	AWG 14	AWG 14
3.8-1	AWG 12	AWG 12	AWG 12
5.0-1	AWG 8	AWG 10	AWG 12
6.0-1	AWG 8	AWG 8	AWG 10
7.5-1	AWG 6	AWG 6	AWG 8
10.0-1	AWG 4	AWG 4	AWG 6
11.4-1	AWG 4	AWG 4	AWG 4
11.4-3	AWG 8	AWG 8	-
12.0-3	-	-	AWG 12

Minimum cross section of AC wires (all calculations based on ambient temperature of 122 °F / 50 °C).

Safety

Only an authorized electrician is permitted to connect this inverter to the public grid.

WARNING! An electrical shock can be fatal. Danger from grid voltage and DC voltage from solar modules.

- The connection area should only be opened by a licensed electrician.
- The separate power stage set area should only be disconnected from the connection area after first being disconnected from the grid power.



Never work with live wires! Prior to all connection work, make sure that the AC and DC wires are not charged.

Connecting the Fronius IG Plus to the Public Grid (AC)

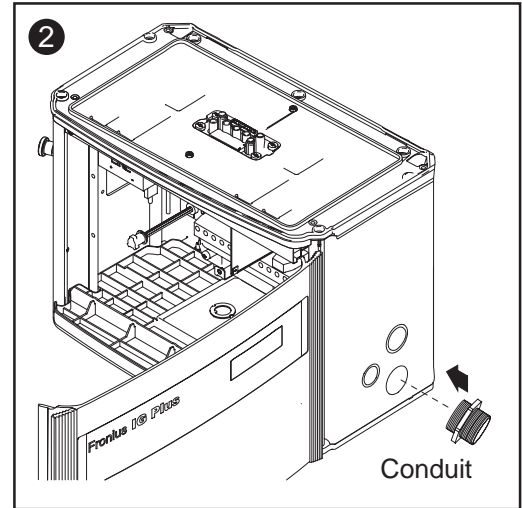
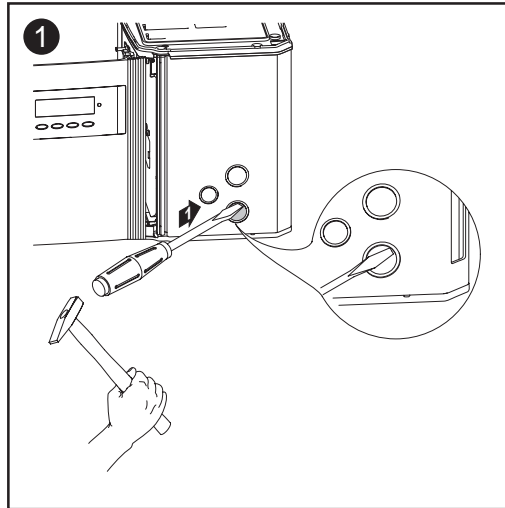

NOTE Only use water tight conduit fittings and conduits. Conduit fittings and conduits are not part of the scope of delivery for the inverter

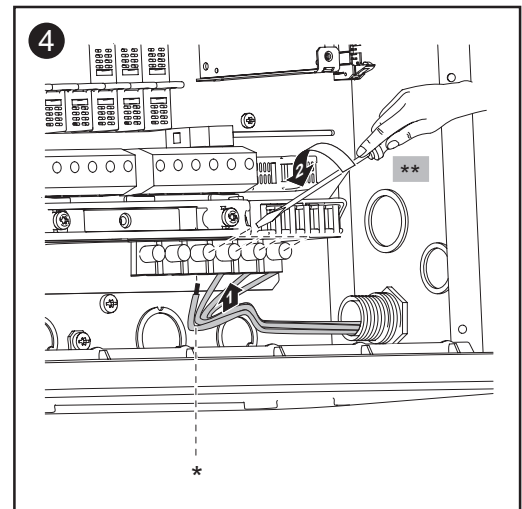
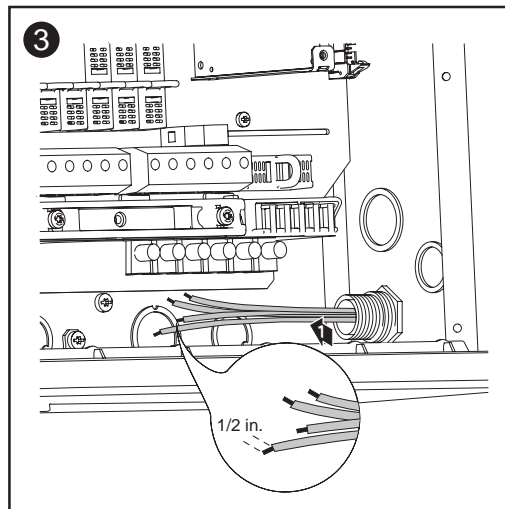

- * Connect grid grounding / grounding conductor to the right terminal
- ** Tightening torque:
 - stranded wires 1.25 ft. lb.
 - solid wires 0.81 ft. lb.

Connect the AC wires to the AC-side terminals depending on the power grid and phase quantity of the inverter:

1 phase - 208 V / 240 V

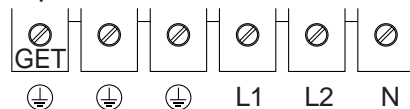

1 phase - 277 V

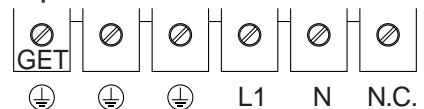

3 phases - 208 V / 240 V / 277 V

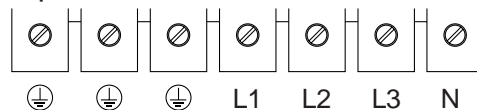

GET = Grounding Electrode Terminal
N.C. = Not connected



NOTE Form a min. 4 in. wire loop using all wires.

Connecting Grounding Electrode Wire

If the photovoltaic system requires a grounding electrode, it should be connected as follows:

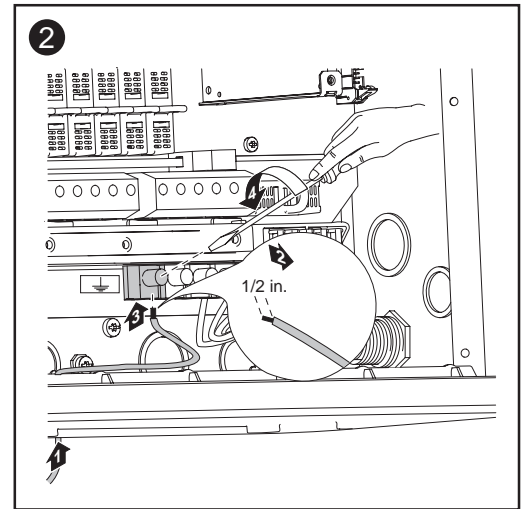
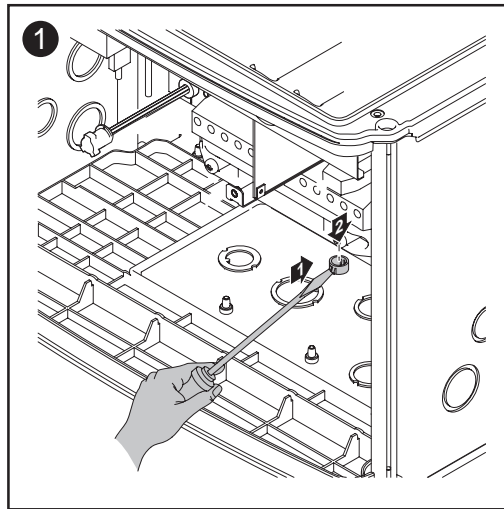

Tightening torque:
 stranded wires 1.25 ft. lb.
 solid wires 0.81 ft. lb.



NOTE

Form a min. 4 in. wire loop with the wire.

Recommendation for the AC-side over current protection



NOTE To reduce the risk of fire, connect only to a circuit provided with branch circuit overcurrent protection in accordance with the National Electrical Code, ANSI / NFPA 70, at a MAXIMUM of:

Fronius IG Plus	Over Current Protection		
	208 V	240 V	277 V
3.0-1	20 A	20 A	15 A
3.8-1	25 A	20 A	20 A
5.0-1	30 A	30 A	25 A
6.0-1	40 A	35 A	30 A
7.5-1	45 A	40 A	35 A
10.0-1	60 A	60 A	45 A
11.4-1	70 A	60 A	60 A
11.4-3	40 A	35 A	-
12.0-3	-	-	20 A

Additional External AC and/or DC Disconnect

Depending on the installation, an additional external AC and/or DC disconnect may be required if the inverter is installed in a location not easily accessible to utility or fire personnel. Consult local authorities for additional information.

Connecting Solar Module Strings to the Fronius IG Plus (DC)

General Information About Solar Modules

In order to select suitable solar modules and get the most efficient use out of the Fronius IG Plus, please note the following points:

- The open circuit voltage increases when temperature decreases (assuming constant irradiance of 1000 W/m²). The inverter open-circuit voltage should never rise above 600 Volts. Whenever the open-circuit voltage of the solar modules exceeds 600 Volts, the Fronius IG Plus unit may be damaged, and all warranty rights will become null and void.
- More exact data for sizing the solar array for the particular location can be obtained using calculation tools such as the Fronius Configuration Tool (available on <http://www.fronius-usa.com>).
- See NEC table 690.7 for the appropriate code-related voltage adjustment factor for crystalline silicon modules, or use the manufacturer's specified voltage coefficient.

Safety



WARNING! An electrical shock can be fatal. Danger from grid voltage and DC voltage from solar modules.

- The connection area should only be opened by a licensed electrician.
- The separate power stage set area should only be disconnected from the connection area after first being disconnected from the grid power.
- The separate power stage set area should only be opened by Fronius-trained service personnel.

Never work with live wires! Prior to all connection work, make sure that the AC and DC wires are not charged.

The DC main switch is only used to switch off power to the power stage set. When the DC main switch is turned off, the connection area is still energized.

DC-Terminals

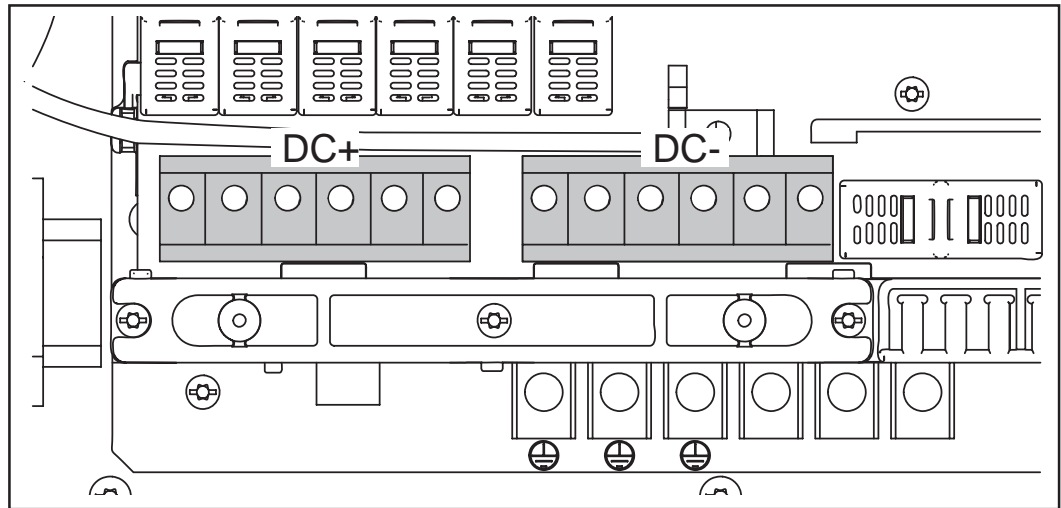

DC+ and DC- terminals on the Fronius IG Plus

Overview

'Connecting Solar Module Strings to the Fronius IG Plus (DC)' includes the following sections:

- Connecting Solar Module Strings
- Criteria for the Proper Selection of String Fuses
- Connecting combined Solar Module Strings using a DC String Input Combiner
- Solar Module Ground at Positive Pole: Connecting Solar Module Strings
- Criteria for the Proper Selection of String Fuses
- Solar Module Ground at Positive Pole: Connecting combined Solar Module Strings using a DC String Input Combiner

Connecting Solar Module Strings

Solar Module Ground

The Fronius IG Plus is designed for a solar module ground at the negative pole. The solar module ground is carried out via a fuse in the inverter.

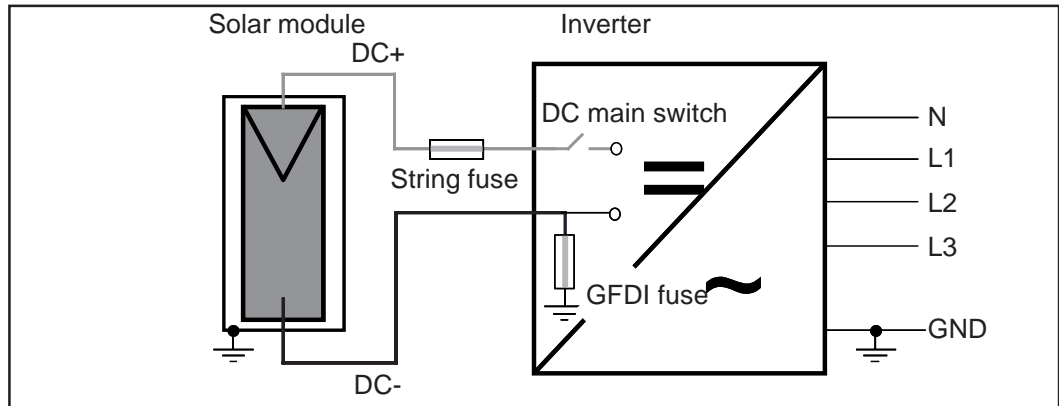

Solar module ground at negative pole with fuse



WARNING! An electric shock can be fatal. Normally grounded conductors may be ungrounded and energized when a ground fault is indicated. The ground fault has to be repaired before operation is resumed.



NOTE Do not connect the ground to the DC negative at any point! This is already done within the Fronius IG Plus. If the DC negative is connected to ground at the DC terminal block or prior, this will circumvent the GFDI protection system, preventing your Fronius IG Plus from properly detecting a fault current. Additionally, turning the DC disconnect to the off/open-circuit condition will not disconnect the array from ground, as it only disconnects the DC positive.

Wire Cross Section of Solar Module Strings



WARNING! An electric shock can be fatal. Inadequately sized electrical components can cause serious injuries to persons and damage to (or loss of) property.

- All electrical installations must be in accordance with the National Electrical Code, ANSI/NFPA 70, and any other codes and regulations applicable to the installation site.
- For installations in Canada the installations must be done in accordance with applicable Canadian standards.
- Use copper wire for all grounding wires
- For appropriate grounding see NEC Section 250.

Wire Cross Section of Solar Module Strings
(continued)



WARNING! An electric shock can be fatal. Inadequately sized electrical components can cause serious injuries to persons and damage to (or loss of) property.

- Use minimum AWG 14 to maximum AWG 6, min. 167°F (75°C), copper wire for all DC wiring connections to the Fronius IG Plus. Voltage drop and other considerations may dictate larger size wires be used.
- Use only solid or stranded wire. Do not use fine stranded wire

Connecting Solar Module Strings

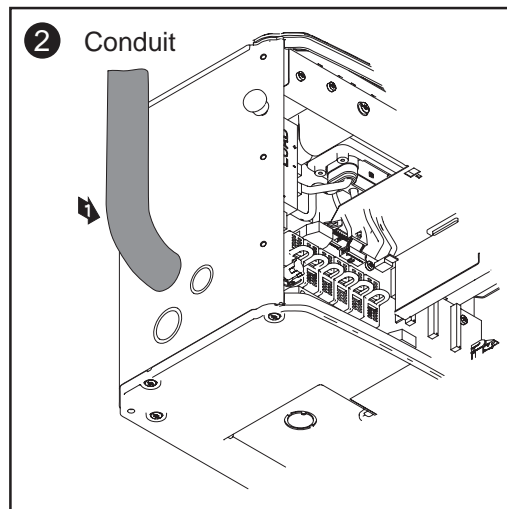
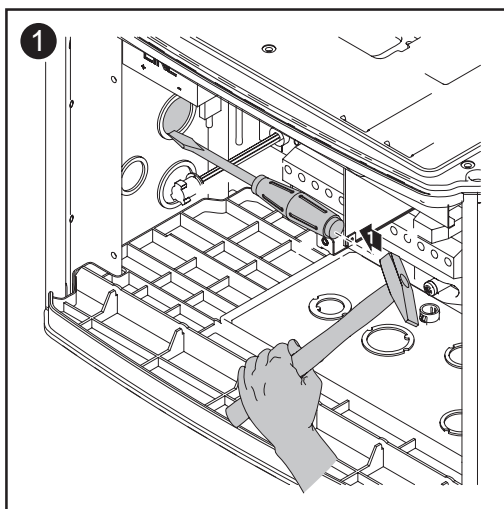

NOTE Only use water tight conduit fittings and conduits. Conduit fittings and conduits are not part of the scope of delivery for the inverter.



CAUTION! Danger of damaging the inverter by overload. Connect a maximum of 20 A to one single DC input terminal.

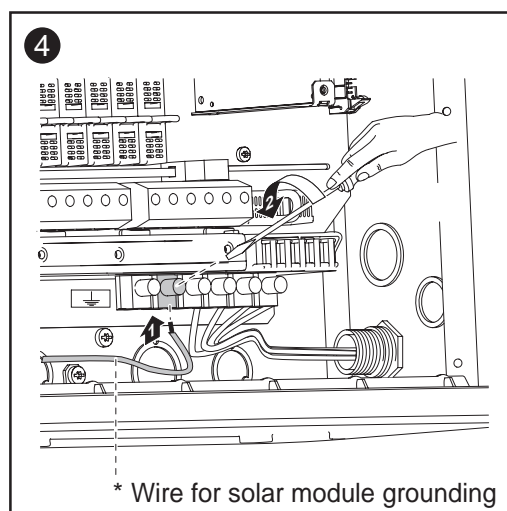
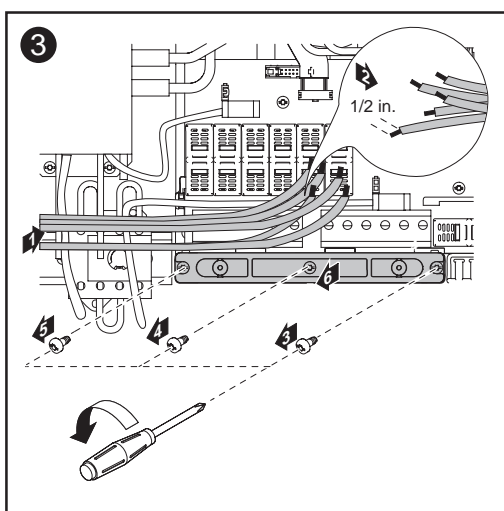

Tightening torque:
 stranded wires 1.25 ft. lb.
 solid wires 0.81 ft. lb.

Connecting Solar Module Strings (continued)

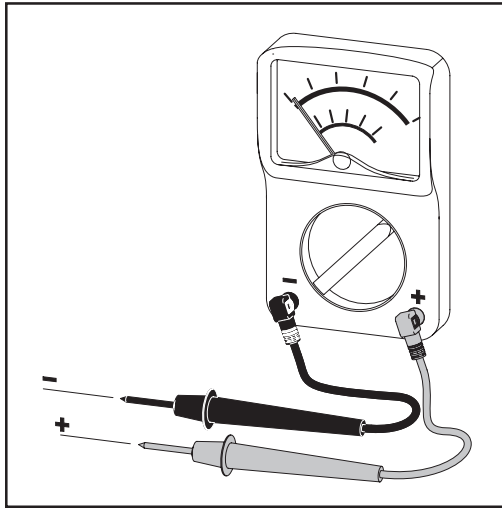

NOTE Connecting the DC wiring with the wrong polarity may cause damage to the inverter. Check both the polarity and the open circuit voltage.

The DC Voltage must not exceed 600 V, regardless of temperature.

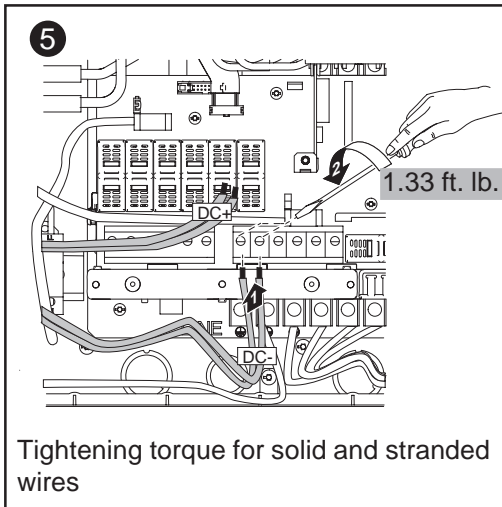

Tightening torque for solid and stranded wires

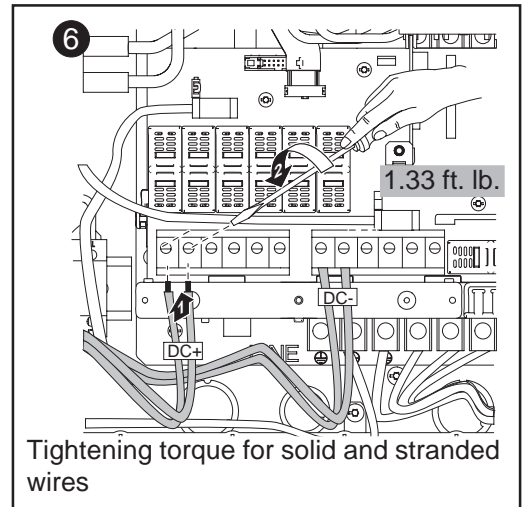

Tightening torque for solid and stranded wires

NOTE Form a min. 4 in. wire loop using all wires.

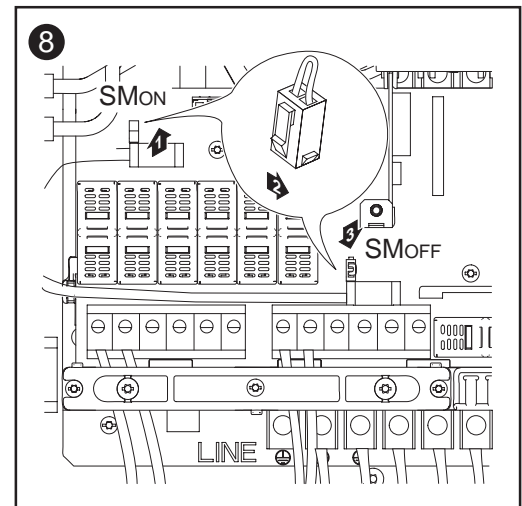
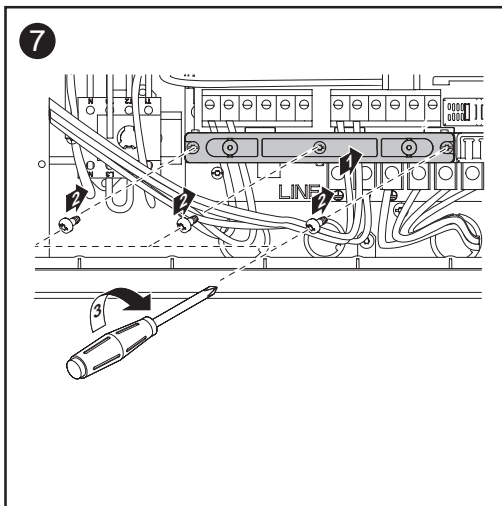

Important

- Set the jumper from the 'SMON' position to the 'SMOFF' position for correct measurement results
- Check the polarity and voltage of the solar module strings: the DC-voltage must not exceed 600 V, the difference between the individual solar module strings should be less than 10 V.

Connecting Solar Module Strings (continued)

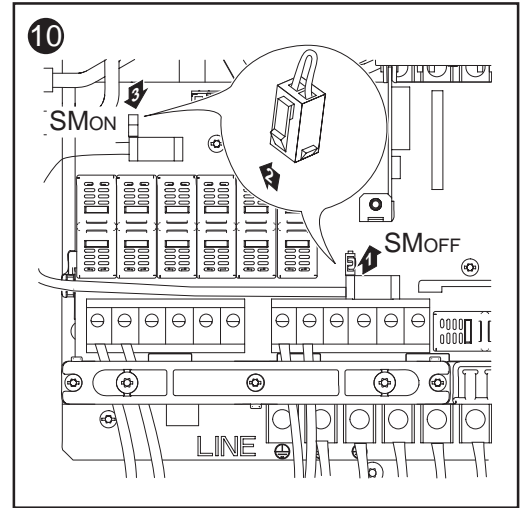
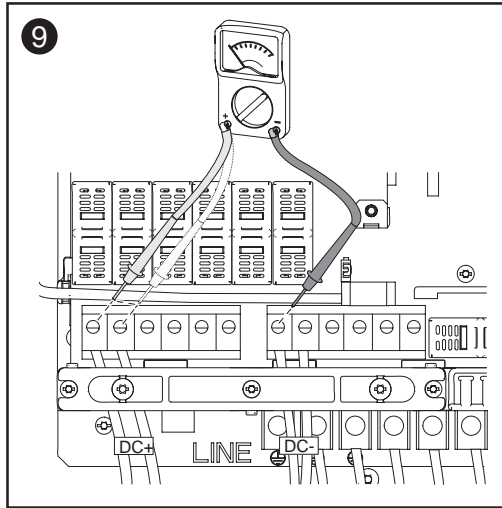

Inserting String fuses into the Fronius IG Plus

Important The Fronius IG Plus is shipped with conductive slugs in the fuseholders. Series fusing may be required depending on the type of PV module used in the system. See NEC 690.9.

- 1 Select string fuses according to the information from the solar module manufacturer or as per 'Criteria for the Proper Selection of String Fuses' (max. 20 A per single DC input terminal)

Important

- Follow all solar module safety instructions
- Follow all solar module manufacturer requirements



WARNING! An electrical shock can be fatal. Danger from DC voltage from solar modules. Fuse covers are for installation purposes only. They offer no protection against contact.



NOTE

- Insert fuses only with a fuse cover in the respective fuse holder
- Do not operate the Fronius IG Plus without fuse covers

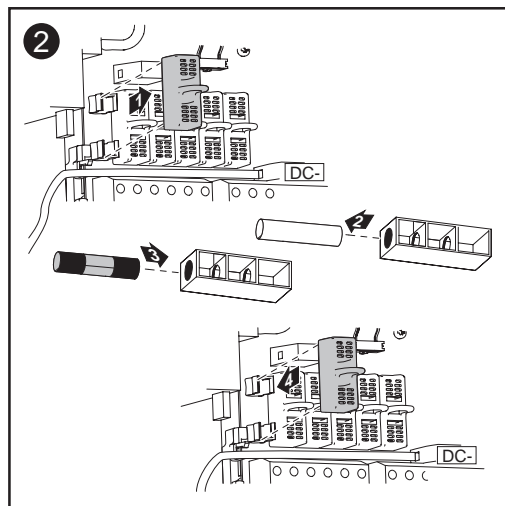

Criteria for the Proper Selection of String Fuses

DC disconnect requirements NEC 690.15-18 allows the use of fuse holders as a suitable means of disconnecting PV arrays for servicing. Additional DC disconnects external to the inverter may be required by the local authority having jurisdiction.

General The use of string fuses in the inverter also adds fuse protection to the solar modules.
A crucial factor for the fuse protection of solar modules is the maximum short circuit current (I_{SC}) of the respective solar module.

Criteria for the Proper Selection of String Fuses The following criteria must be fulfilled for each solar module string when using fuse protection:

- $I_N > 1.56 \times I_{SC}$
- $I_N < 2.00 \times I_{SC}$
- $V_N \geq 600 \text{ V DC}$
- Fuse dimensions: Diameter 10.3 x 35 - 38 mm

I_N Nominal current rating of fuse

I_{SC} short circuit current for standard test conditions (STC) according to solar module data sheet

V_N Nominal voltage rating of fuse



NOTE The string fuse size must not be greater than the maximum fuse size rating of the PV module as provided on the PV module manufacturers data sheet. If no maximum fuse size is indicated, please contact the PV module manufacturer.

Effects of using underrated fuses In underrated fuses, the nominal current value is less than the short circuit current of the solar module.
Effect:
The fuse may trip in intensive irradiance conditions.

Fuse Recommendations - Application Example



NOTE

Only select fuses suitable for a voltage of 600 V DC.

Example:

Maximum short circuit current (I_{sc}) of the solar module = 5.75 A

According to the criteria for selecting the correct fuse, the fuse must have a nominal current greater than 1.5 times the short circuit current:

$$5.75 \text{ A} \times 1.56 = 8.97 \text{ A}$$

The fuse that should be selected according to the 'Fuses' table: KLK D 9 with 9.0 A and 600 V AC / DC

Fuses

Nominal current value	Fuse	Nominal current value	Fuse
1.0 A	KLK D 1	6.0 A	KLK D 6
1.5 A	KLK D 1 1/2	7.0 A	KLK D 7
2.0 A	KLK D 2	8.0 A	KLK D 8
2.5 A	KLK D 2 1/2	9.0 A	KLK D 9
3.0 A	KLK D 3	10.0 A	KLK D 10
3.5 A	KLK D 3 1/2	12.0 A	KLK D 12
4.0 A	KLK D 4	15.0 A	KLK D 15
5.0 A	KLK D 5	20.0 A	KLK D 20

'Fuses' table: Excerpt of suitable fuses, e.g. Littelfuse fuses

Connecting combined Solar Module Strings using a DC String Input Combiner

General

When more solar module strings are combined to one solar module string prior to the inverter, the solar module string current may exceed the permissible DC input terminal current rating of 20 A.

In this case the DC cables can be connected to the Fronius IG Plus using a string input combiner as an option.

Additional Required Components

The following additional components are required for connecting combined solar module strings using a DC string input combiner:

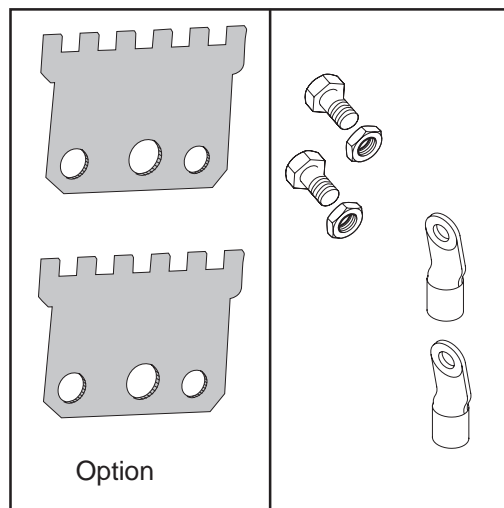

- 2 string input combiners (available from Fronius as an option)
 - cable lugs
- select cable lugs that match the available DC cables
- hexagon screws
 - hexagon nuts
- matching the cable lugs

Additional required components

Solar Module Ground

The Fronius IG Plus is designed for a solar module ground at the negative pole. The solar module ground is carried out via a fuse in the inverter.

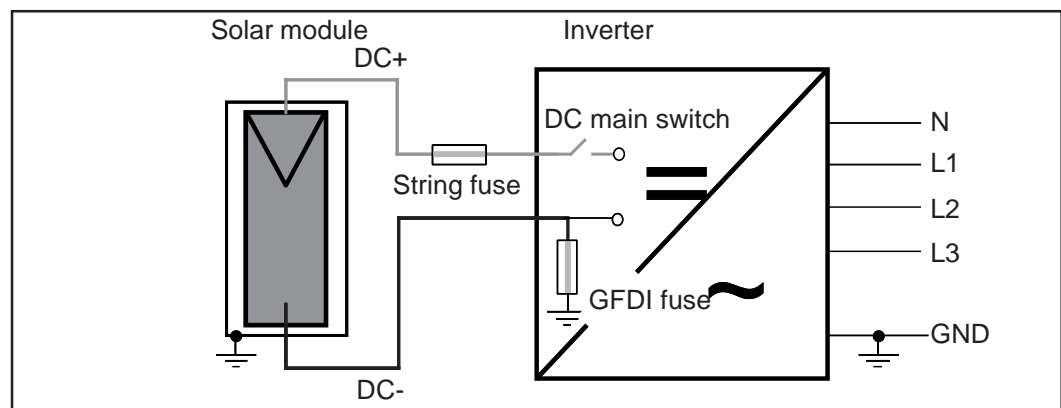

Solar module ground at negative pole with fuse

Solar Module Ground (continued)



WARNING! An electric shock can be fatal. Normally grounded conductors may be ungrounded and energized when a ground fault is indicated. The ground fault has to be repaired before operation is resumed.



NOTE Do not connect the ground to the DC negative at any point! This is already done within the Fronius IG Plus. If the DC negative is connected to ground at the DC terminal block or prior, this will circumvent the GFDI protection system, preventing your Fronius IG Plus from properly detecting a fault current. Additionally, turning the DC disconnect to the off/open-circuit condition will not disconnect the array from ground, as it only disconnects the DC positive.

Safety



WARNING! An electric shock can be fatal. Inadequately sized electrical components can cause serious injuries to persons and damage to (or loss of) property.

- All electrical installations must be in accordance with the National Electrical Code, ANSI/NFPA 70, and any other codes and regulations applicable to the installation site.
- For installations in Canada the installations must be done in accordance with applicable Canadian standards.
- Use copper wire for all grounding wires
- For appropriate grounding see NEC Section 250.
- Use only solid or stranded wire. Do not use fine stranded wire

Connecting combined Solar Module Strings using a DC String Input Combiner

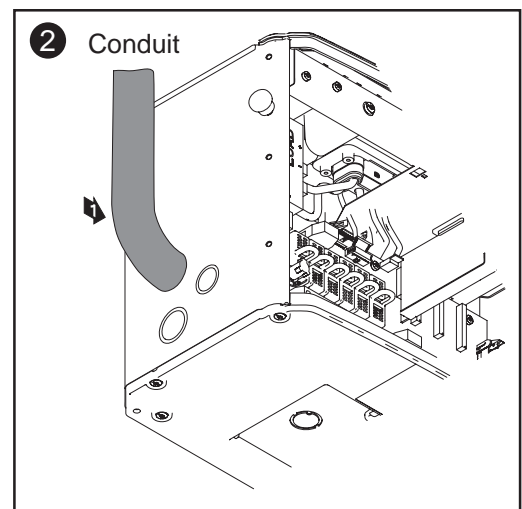
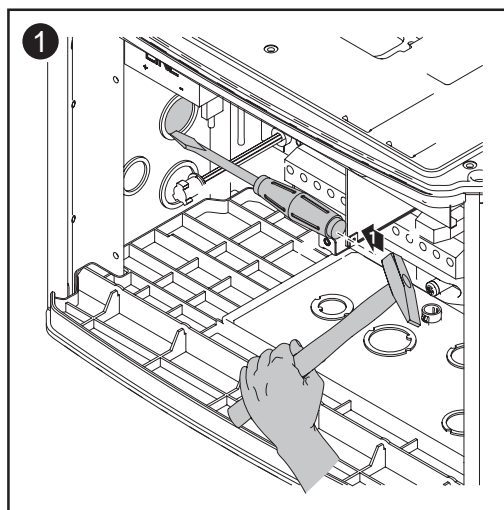

NOTE Only use water tight conduit fittings and conduits. Conduit fittings and conduits are not part of the scope of delivery for the inverter.

Connecting combined Solar Module Strings using a DC String Input Combiner
(continued)

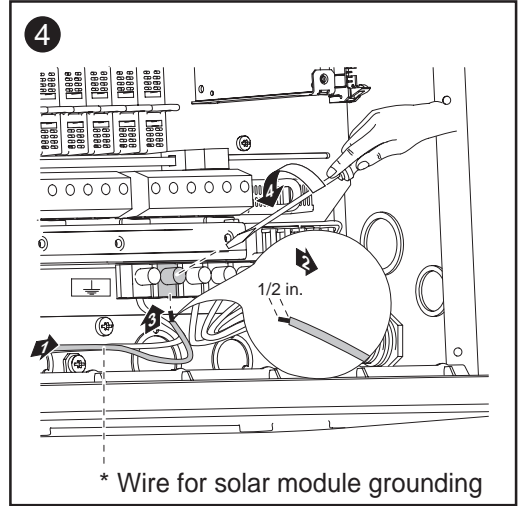
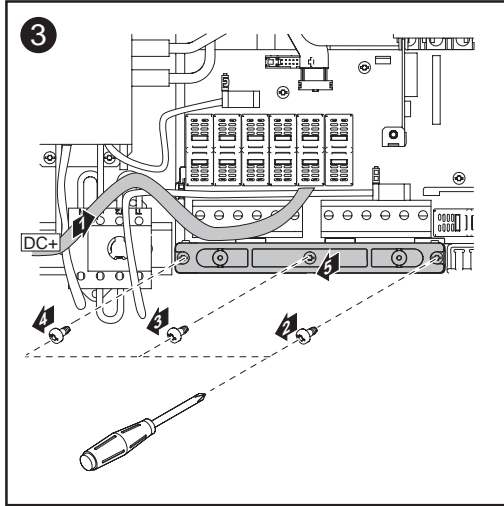

Tightening torque:
stranded wires 1.25 ft. lb.
solid wires 0.81 ft. lb.

NOTE Connecting the DC wiring with the wrong polarity may cause damage to the inverter. Check both the polarity and the open circuit voltage.

The DC Voltage must not exceed 600 V, regardless of temperature.

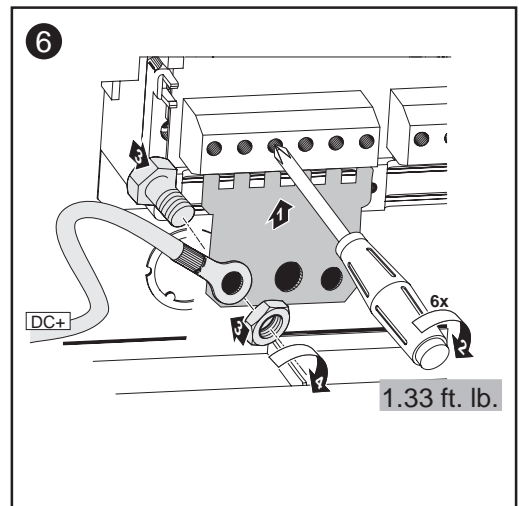
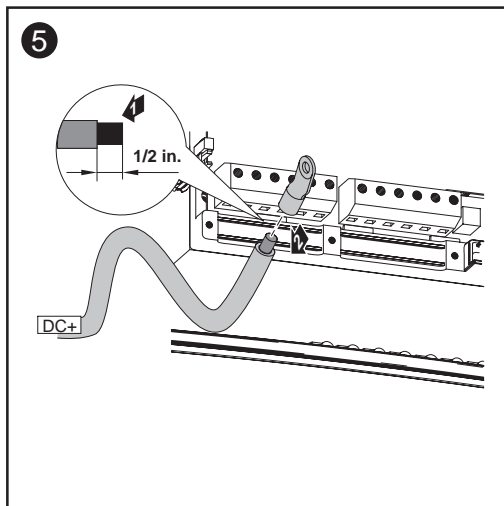
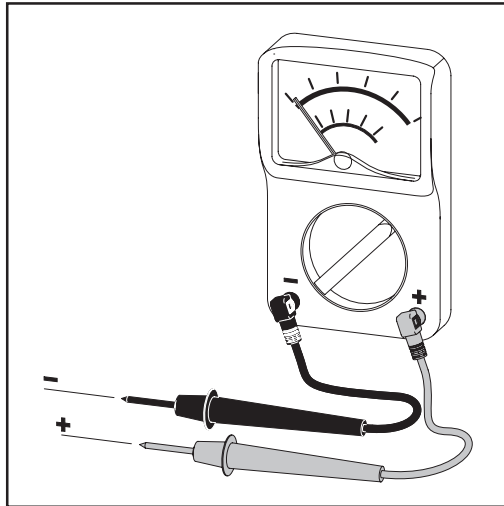

Connecting combined Solar Module Strings using a DC String Input Combiner
(continued)

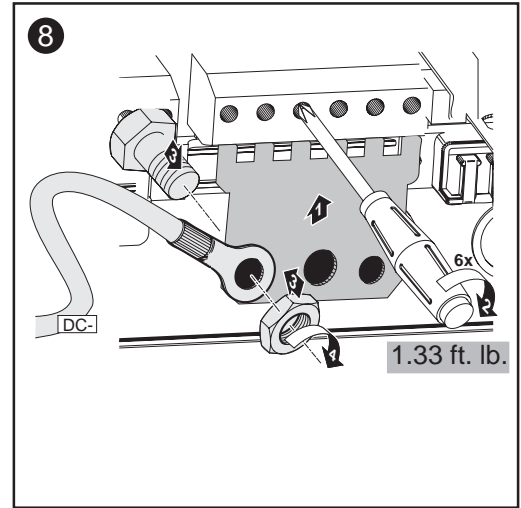
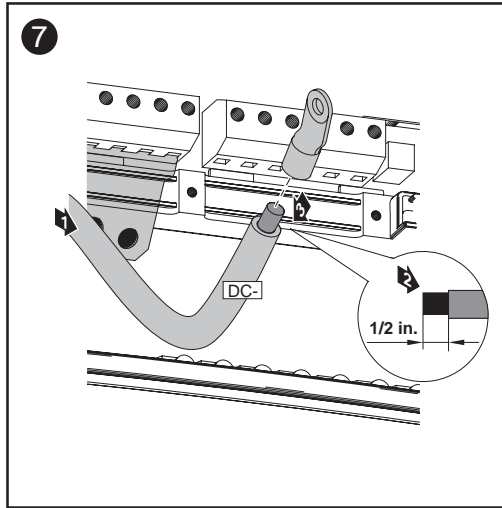

NOTE

Form a min. 4 in. wire loop using all wires.



CAUTION! Danger of damaging the inverter by overload. Before starting up the inverter make sure, that a conductive slug is inserted in each fuse holder for string fuses.

- Insert conductive slugs only with a fuse cover in the respective fuse holder
- Do not operate the Fronius IG Plus without fuse covers

Solar Module Ground at Positive Pole: Connecting Solar Module Strings

General

The following steps are necessary when the solar module manufacturer requires a solar module ground at the positive pole.

Solar Module Ground at Positive Pole

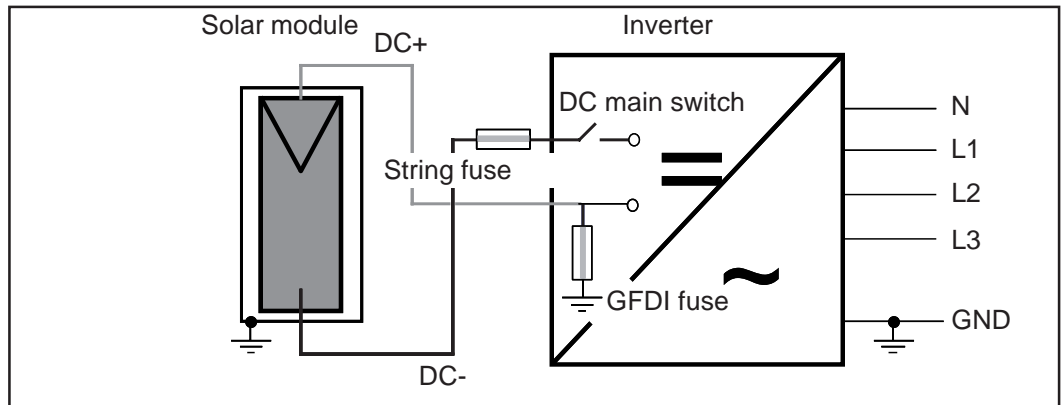

Solar module ground at positive pole with fuse



WARNING! An electric shock can be fatal. Normally grounded conductors may be ungrounded and energized when a ground fault is indicated. The ground fault has to be repaired before operation is resumed.



NOTE Do not connect the ground to the DC positive at any point! This is already done within the Fronius IG Plus. If the DC positive is connected to ground at the DC terminal block or prior, this will circumvent the GFDI protection system, preventing your Fronius IG Plus from properly detecting a fault current. Additionally, turning the DC disconnect to the off/open-circuit condition will not disconnect the array from ground, as it only disconnects the DC negative.

Wire Cross Section of Solar Module Strings



WARNING! An electric shock can be fatal. Inadequately sized electrical components can cause serious injuries to persons and damage to (or loss of) property.

- Electrical installations must be in accordance with the National Electrical Code, ANSI/NFPA 70, and any other codes and regulations applicable to the installation site.
- For installations in Canada the installations must be done in accordance with applicable Canadian standards.
- Use copper wire for all grounding wires
- For appropriate grounding see NEC Section 250.

Wire Cross Section of Solar Module Strings
(continued)



WARNING! An electric shock can be fatal. Inadequately sized electrical components can cause serious injuries to persons and damage to (or loss of) property.

- Use minimum AWG 14 to maximum AWG 6, min. 167°F (75°C), copper wire for all DC wiring connections to the Fronius IG Plus. Voltage drop and other considerations may dictate larger size wires be used.
- Use only solid or stranded wire. Do not use fine stranded wire.

Solar Module Ground at Positive Pole: Connecting Solar Module Strings

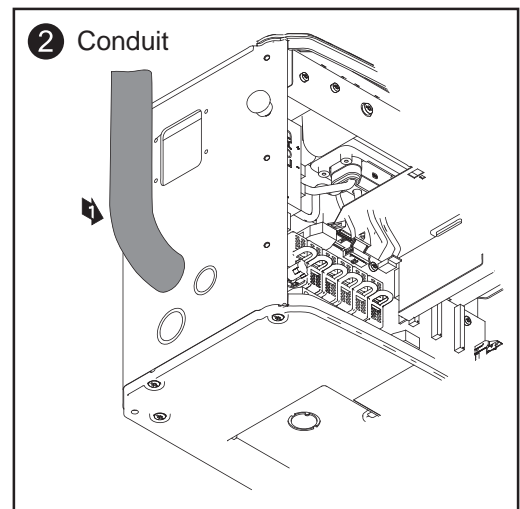
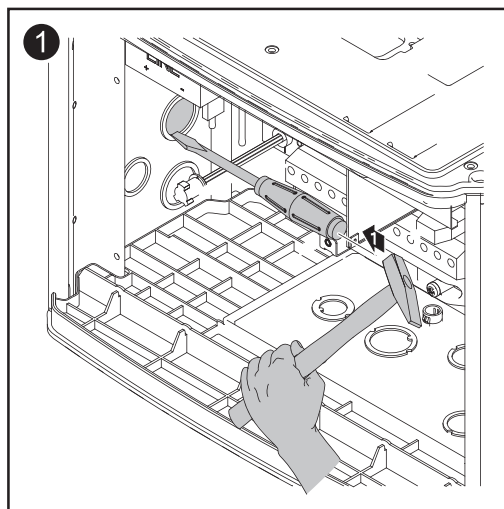

NOTE Only use water tight conduit fittings and conduits. Conduit fittings and conduits are not part of the scope of delivery for the inverter.

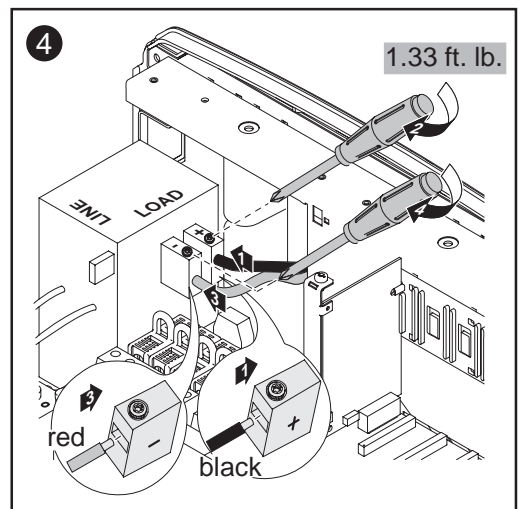
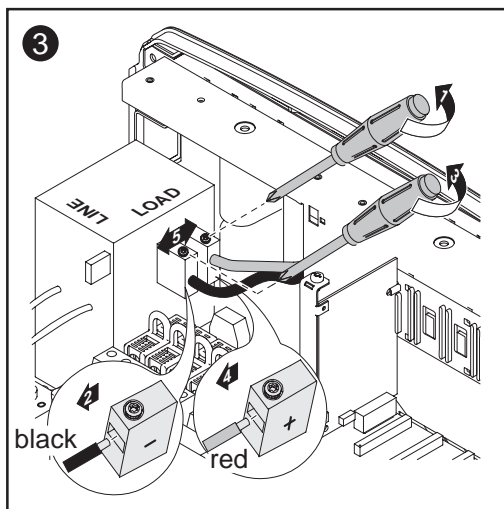

After disconnecting the DC filter wire:

- Connect the red DC+ wire to the DC- filter terminal as per step 4
- Connect the black DC- wire to the DC+ filter terminal as per step 4



NOTE Identify the reversed polarity accordingly with (+) and (-) at the DC input terminal blocks.

Solar Module Ground at Positive Pole: Connecting Solar Module Strings
(continued)

CAUTION! Danger of damaging the inverter by overload. Connect a maximum of 20 A to one single DC input terminal.

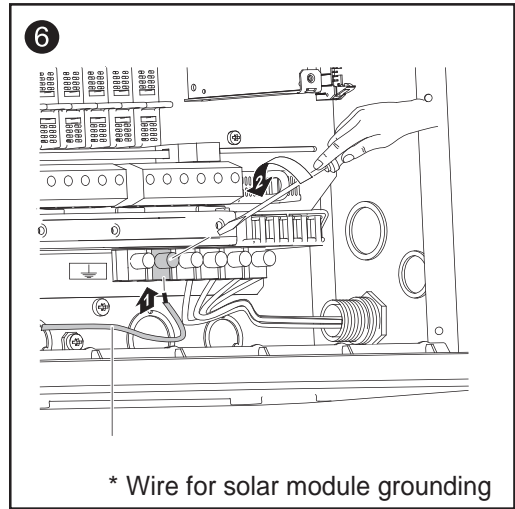
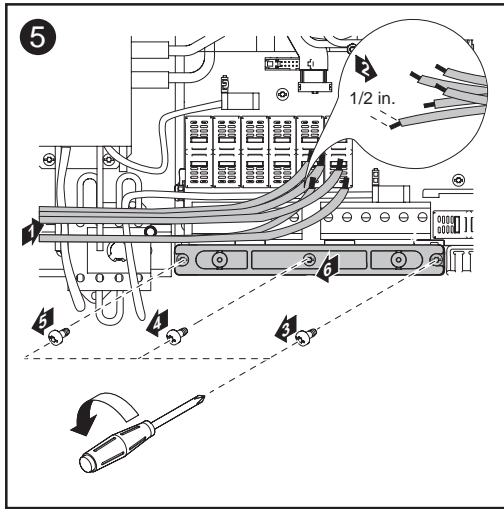

Tightening torque:
stranded wires 1.25 ft. lb.
solid wires 0.81 ft. lb.

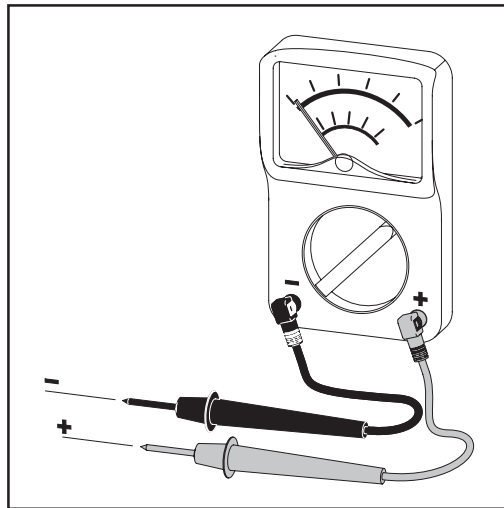

NOTE Connecting the DC wiring with the wrong polarity may cause damage to the inverter.

Check both the polarity and the open circuit voltage.

The DC Voltage must not exceed 600 V, regardless of temperature.

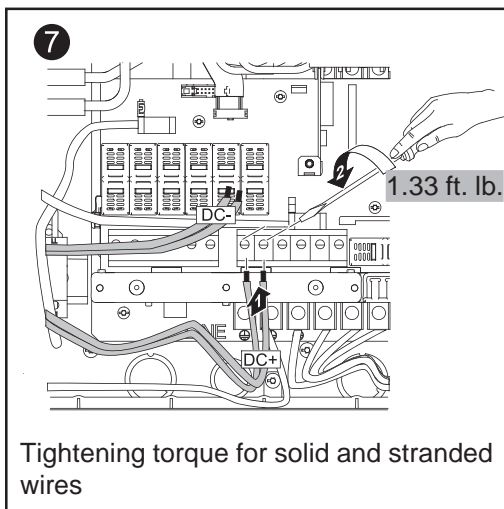

Tightening torque for solid and stranded wires

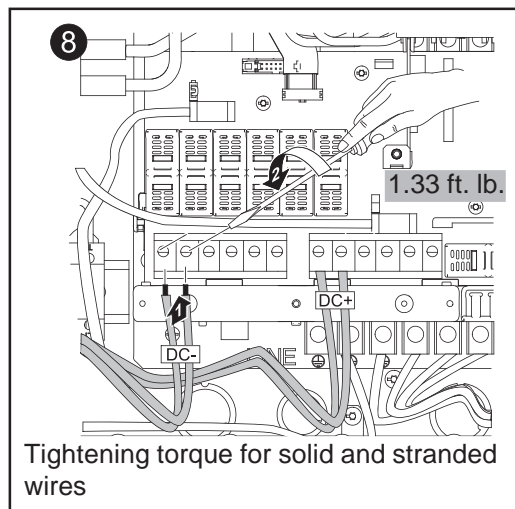

Tightening torque for solid and stranded wires

NOTE Form a min. 4 in. wire loop using all wires.

Solar Module Ground at Positive Pole: Connecting Solar Module Strings
(continued)

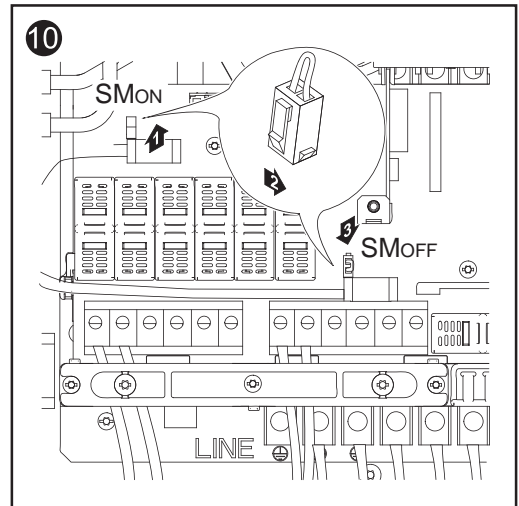
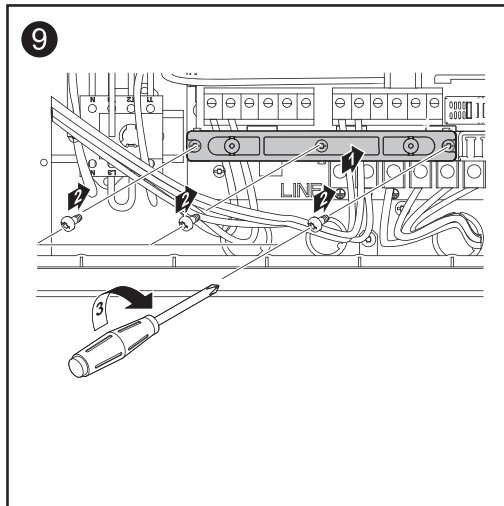

Important

- Set the jumper from the 'SMON' position to the 'SMOFF' position for correct measurement results
- Check the polarity and voltage of the solar module strings: the DC-voltage must not exceed 600 V, the difference between the individual solar module strings should be less than 10 V.

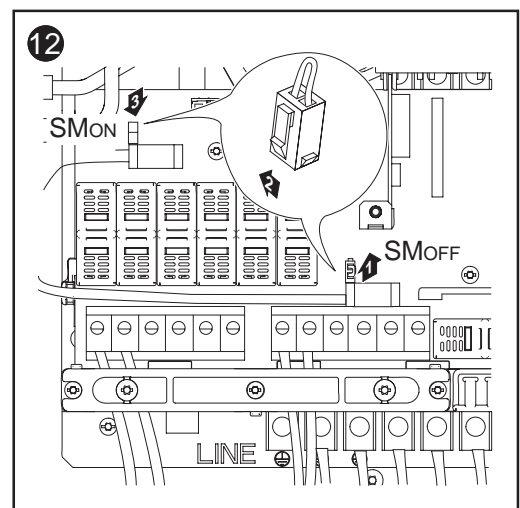
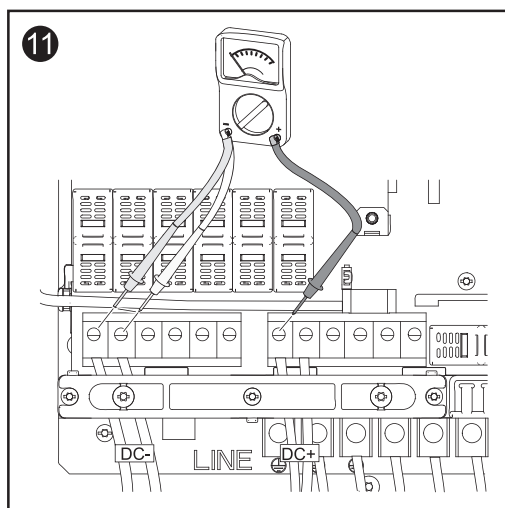

Solar Module Ground at Positive Pole: Inserting String fuses into the Fronius IG Plus

Important The Fronius IG Plus is shipped with conductive slugs in the fuseholders. Series fusing may be required depending on the type of PV module used in the system. See NEC 690.9.

- 1 Select string fuses according to the information from the solar module manufacturer or as per 'Criteria for the Proper Selection of String Fuses' (max. 20 A per single DC input terminal)

Important

- Follow all solar module safety instructions
- Follow all solar module manufacturer requirements

**Solar Module
Ground at
Positive Pole:
Inserting
String fuses
into the Froni-
us IG Plus**
(continued)



WARNING! An electrical shock can be fatal. Danger from DC voltage from solar modules.
Fuse covers are for installation purposes only. They offer no protection against contact.



NOTE

- Insert fuses only with a fuse cover in the respective fuse holder
- Do not operate the Fronius IG Plus without fuse covers

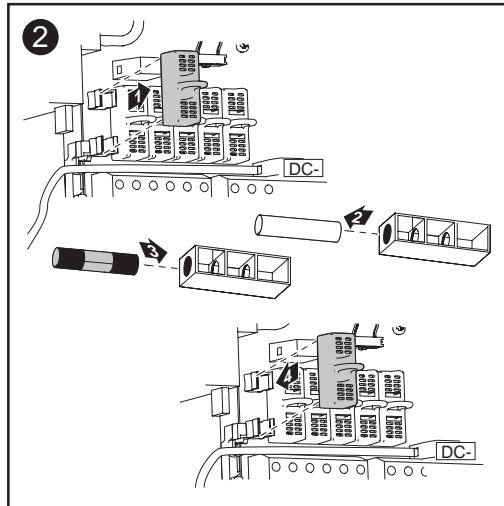

Criteria for the Proper Selection of String Fuses

DC disconnect requirements NEC 690.15-18 allows the use of fuse holders as a suitable means of disconnecting PV arrays for servicing. Additional DC disconnects external to the inverter may be required by the local authority having jurisdiction.

General The use of string fuses in the inverter also adds fuse protection to the solar modules.
A crucial factor for the fuse protection of solar modules is the maximum short circuit current (I_{SC}) of the respective solar module.

Criteria for the Proper Selection of String Fuses The following criteria must be fulfilled for each solar module string when using fuse protection:

- $I_N > 1.56 \times I_{SC}$
- $I_N < 2.00 \times I_{SC}$
- $V_N \geq 600 \text{ V DC}$
- Fuse dimensions: Diameter 10.3 x 35 - 38 mm

I_N Nominal current rating of fuse

I_{SC} short circuit current for standard test conditions (STC) according to solar module data sheet

V_N Nominal voltage rating of fuse



NOTE The string fuse size must not be greater than the maximum fuse size rating of the PV module as provided on the PV module manufacturers data sheet. If no maximum fuse size is indicated, please contact the PV module manufacturer.

Effects of using underrated fuses In underrated fuses, the nominal current value is less than the short circuit current of the solar module.
Effect:
The fuse may trip in intensive irradiance conditions.

Fuse Recommendations - Application Example



NOTE

Only select fuses suitable for a voltage of 600 V DC.

Example:

Maximum short circuit current (I_{sc}) of the solar module = 5.75 A

According to the criteria for selecting the correct fuse, the fuse must have a nominal current greater than 1.5 times the short circuit current:

$$5.75 \text{ A} \times 1.56 = 8.97 \text{ A}$$

The fuse that should be selected according to the 'Fuses' table: KLK D 9 with 9.0 A and 600 V AC / DC

Fuses

Nominal current value	Fuse	Nominal current value	Fuse
1.0 A	KLK D 1	6.0 A	KLK D 6
1.5 A	KLK D 1 $\frac{1}{2}$	7.0 A	KLK D 7
2.0 A	KLK D 2	8.0 A	KLK D 8
2.5 A	KLK D 2 $\frac{1}{2}$	9.0 A	KLK D 9
3.0 A	KLK D 3	10.0 A	KLK D 10
3.5 A	KLK D 3 $\frac{1}{2}$	12.0 A	KLK D 12
4.0 A	KLK D 4	15.0 A	KLK D 15
5.0 A	KLK D 5	20.0 A	KLK D 20

'Fuses' table: Excerpt of suitable fuses, e.g. Littelfuse fuses

Solar Module Ground at Positive Pole: Connecting combined Solar Module Strings using a DC String Input Combiner

General

The following work steps are only necessary when the solar module manufacturer requires a solar module ground at the positive pole.

When more solar module strings are combined to one solar module string prior to the inverter, the solar module string current may exceed the permissible DC input terminal current rating of 20 A.

In this case the DC cables can be connected to the Fronius IG Plus using a string input combiner as an option.

Additional Required Components

The following additional components are required for connecting combined solar module strings using a DC string input combiner:

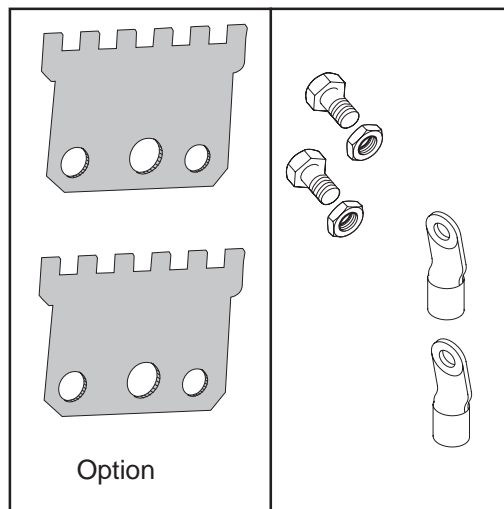

- 2 string input combiners (available from Fronius as an option)
- cable lugs
- select cable lugs that match the available DC cables
- hexagon screws
- hexagon nuts
- matching the cable lugs

Additional required components

Solar Module Ground at Positive Pole

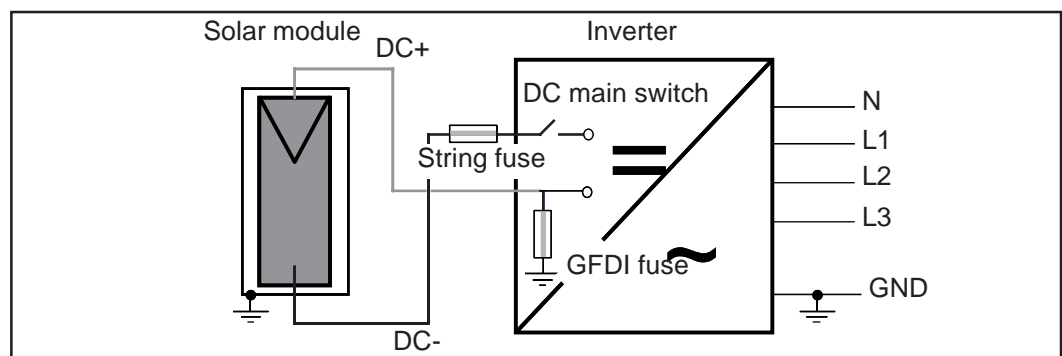

Solar module ground at positive pole with fuse

Solar Module Ground at Positive Pole (continued)



WARNING! An electric shock can be fatal. Normally grounded conductors may be ungrounded and energized when a ground fault is indicated. The ground fault has to be repaired before operation is resumed.



NOTE Do not connect the ground to the DC positive at any point! This is already done within the Fronius IG Plus. If the DC positive is connected to ground at the DC terminal block or prior, this will circumvent the GFDI protection system, preventing your Fronius IG Plus from properly detecting a fault current. Additionally, turning the DC disconnect to the off/open-circuit condition will not disconnect the array from ground, as it only disconnects the DC negative.

Safety



WARNING! An electric shock can be fatal. Inadequately sized electrical components can cause serious injuries to persons and damage to (or loss of) property.

- Electrical installations must be in accordance with the National Electrical Code, ANSI/NFPA 70, and any other codes and regulations applicable to the installation site.
- For installations in Canada the installations must be done in accordance with applicable Canadian standards.
- Use copper wire for all grounding wires
- For appropriate grounding see NEC Section 250.
- Use only solid or stranded wire. Do not use fine stranded wire.

Solar Module Ground at Positive Pole: Connecting combined Solar Module Strings using a DC String Input Combiner

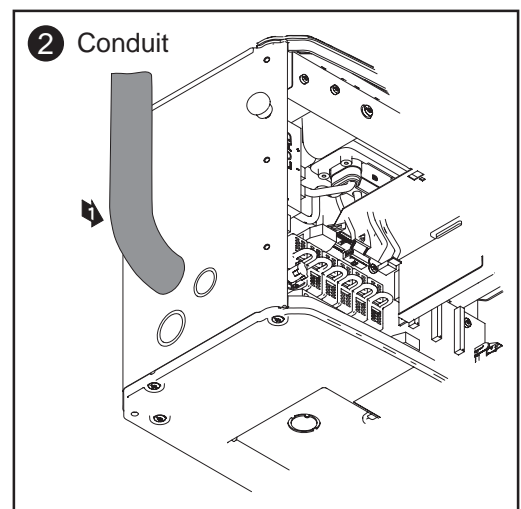
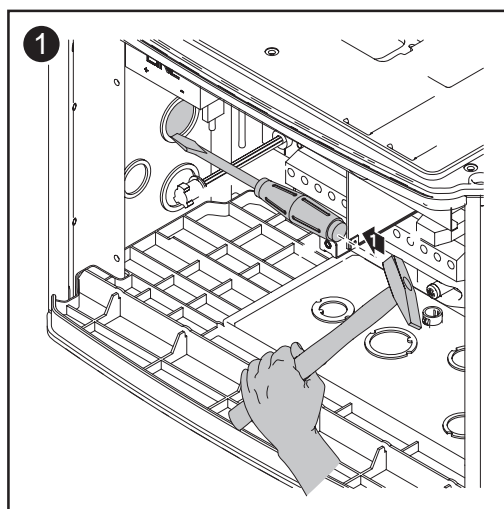

NOTE Only use water tight conduit fittings and conduits. Conduit fittings and conduits are not part of the scope of delivery for the inverter.

Solar Module Ground at Positive Pole: Connecting combined Solar Module Strings using a DC String Input Combiner
(continued)

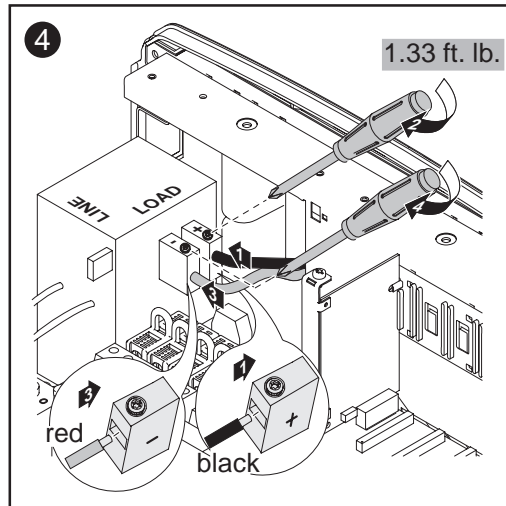
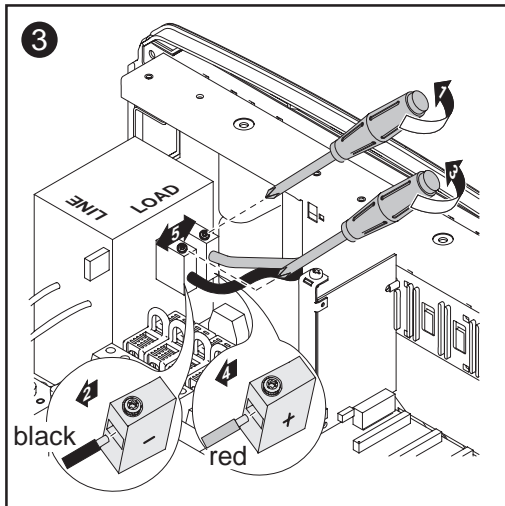

After disconnecting the DC filter wire:

- Connect the red DC+ wire to the DC- filter terminal as per step 4
- Connect the black DC- wire to the DC+ filter terminal as per step 4

NOTE Identify the reversed polarity accordingly with (+) and (-) at the DC input terminal blocks.

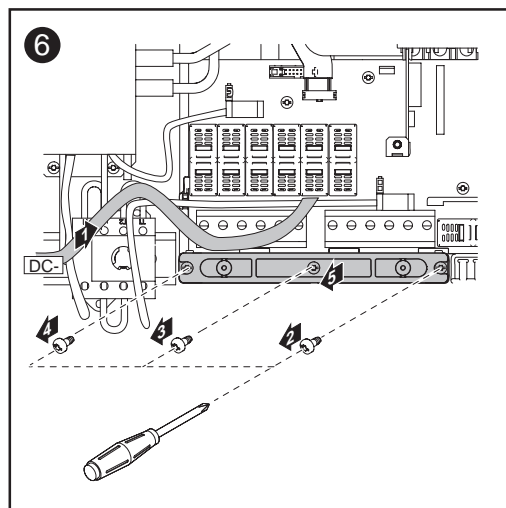
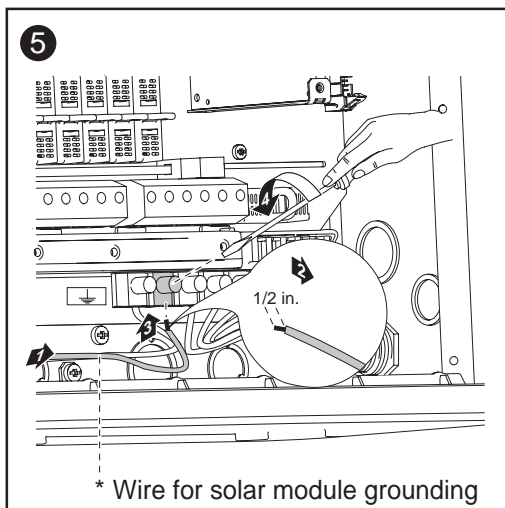

Tightening torque:
stranded wires 1.25 ft. lb.
solid wires 0.81 ft. lb.

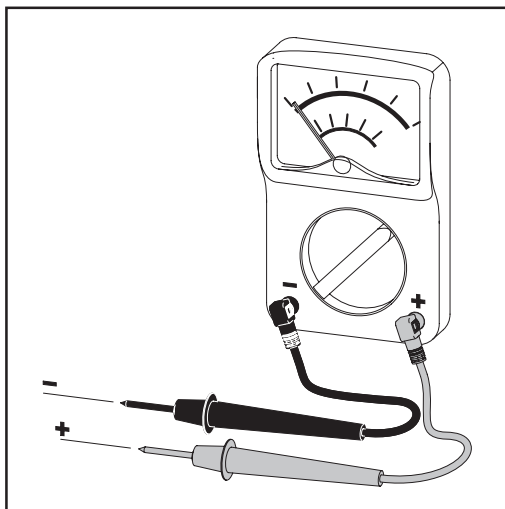

NOTE Connecting the DC wiring with the wrong polarity may cause damage to the inverter. Check both the polarity and the open circuit voltage.

The DC Voltage must not exceed 600 V, regardless of temperature.

Solar Module Ground at Positive Pole: Connecting combined Solar Module Strings using a DC String Input Combiner
(continued)

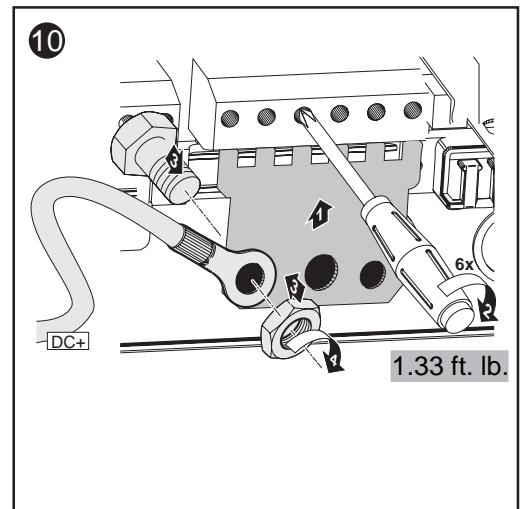
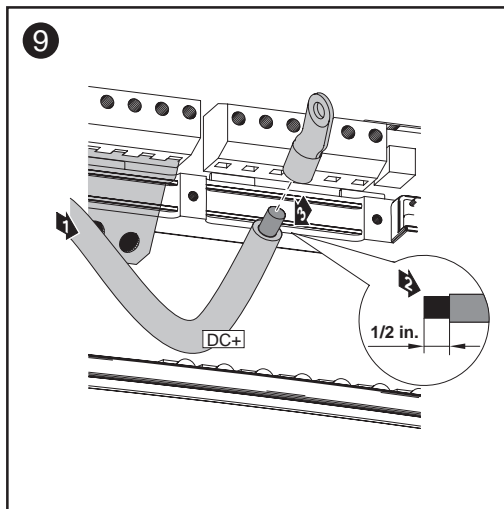
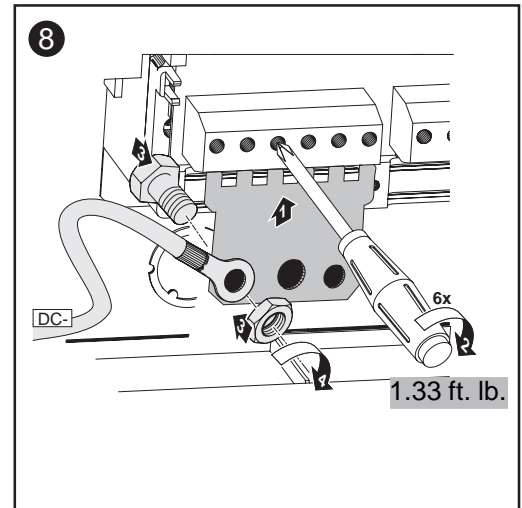
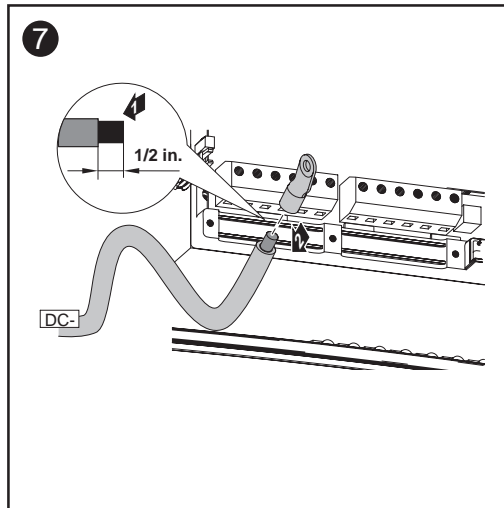

NOTE

Form a min. 4 in. wire loop using all wires.



CAUTION! Danger of damaging the inverter by overload.

Bevore starting up the inverter make sure, that a conductive slug is inserted in each fuse holder for string fuses.

- Insert conductive slugs only with a fuse cover in the respective fuse holder
- Do not operate the Fronius IG Plus without fuse covers

Attaching Power Stage Sets and Closing the Fronius IG Plus

Preparation

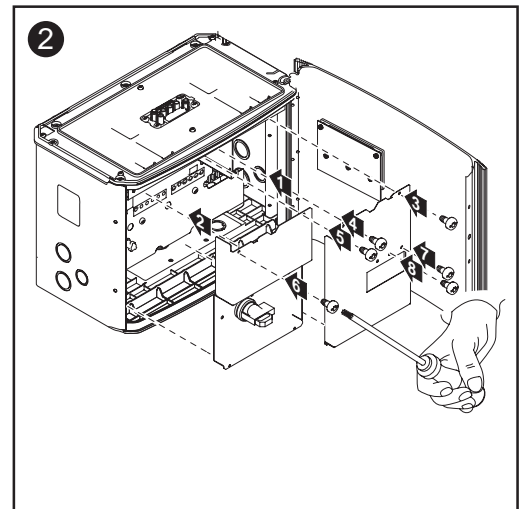
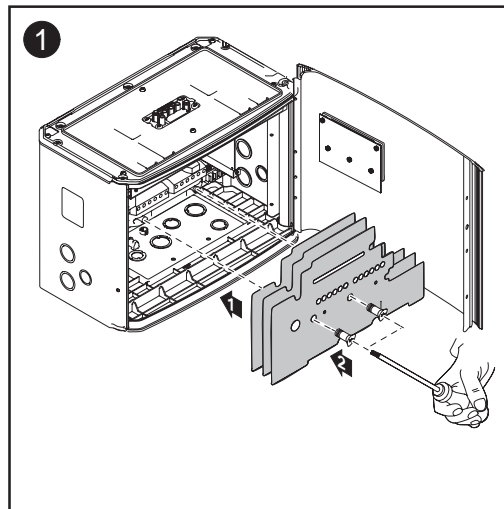

Attaching Power Stage Sets And Closing the Fronius IG Plus

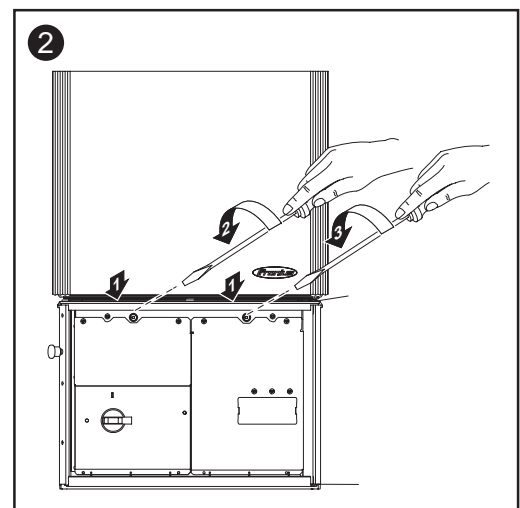
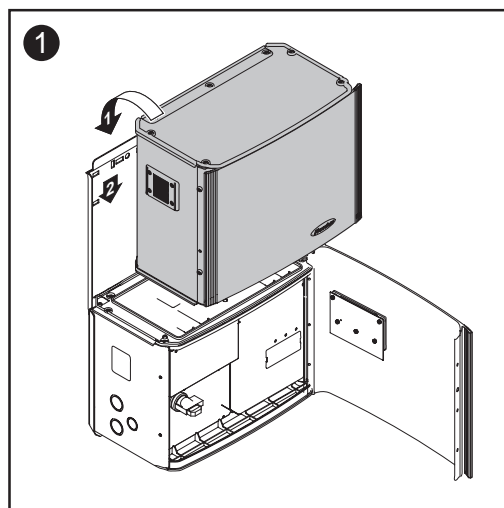

The Fronius IG Plus is now operational.

Opening the Fronius IG Plus for Service/Maintenance

Procedure for opening the Fronius IG Plus for service or maintenance:

1. Disconnect the AC and DC supply from the inverter
2. Open the connection area
3. Turn off DC main switch
4. Allow the capacitors to discharge (5 minutes)
5. Remove metal covers
6. Remove the plastic dividers
7. Remove string fuses
8. Disconnect DC wire
9. Disconnect AC wire

Start up Operation

Factory pre-set configuration

Your Fronius IG Plus unit has been pre-configured in the factory and is ready for operation. You only have to set the available power grid for startup.

To change your inverter settings, please see section 'The Setup Menu' in the chapter 'Operation'.

Requirements for Starting up Operation

- Fronius IG Plus connected to the public grid (AC)
- Fronius IG Plus connected to the solar modules (DC)
- 3 plastic dividers set in
- 2 metal covers mounted
- power stage set mounted



NOTE

Do not operate the Fronius IG Plus without fuse covers.

Start up Operation

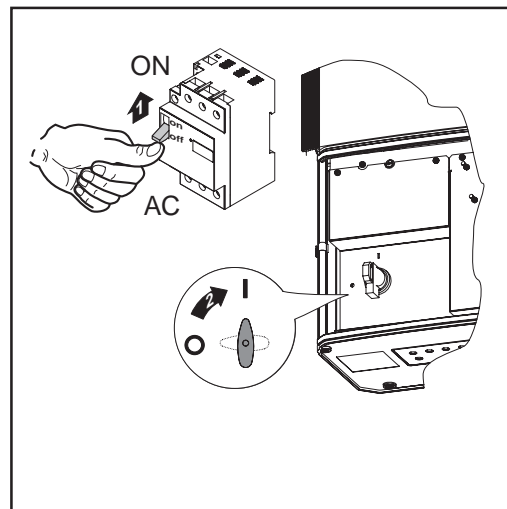

1. Turn on AC disconnect
2. Flip DC main switch to position - 1 -

As soon as the photovoltaic modules produce sufficient power, the Operating Status LED lights up orange.

The orange LED indicates that the feed-in mode of the Fronius IG Plus will begin shortly.

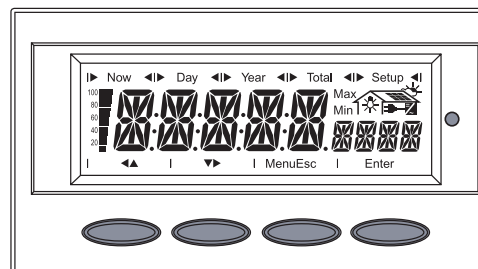

The screen displays the startup phase

- Segment test
All display elements light up for about one second
- The Fronius IG Plus unit goes through a master check list for several seconds



The display shows 'TEST' and indicates the respective component which is being tested (for example 'LED')

Start up Opeation
(continued)

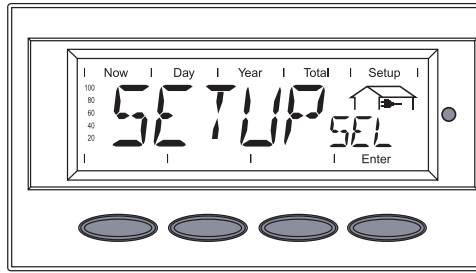

- The grid selection phase begins: 'SETUP_{SEL}' is shown

3. Press the 'Enter' key

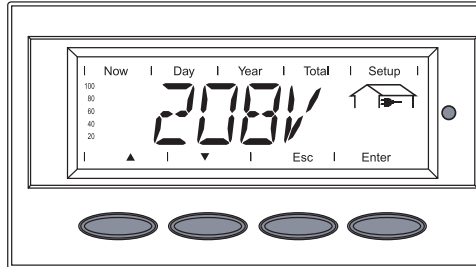

The first grid selection option is shown (e.g.: 208 V)

4. Selecting the public grid

Selecting the public grid

Several grid selection options are displayed depending on the product type (see also section 'Connecting the Fronius IG Plus to the Public Grid').

1. Use the 'Up' and 'Down' keys to select the desired grid
▲ ▼

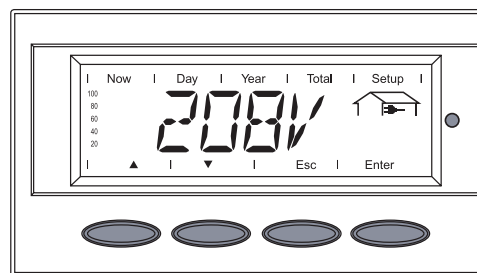

Grid voltage 208 V Delta
No neutral conductor in the system
Neutral conductor monitoring is deactivated

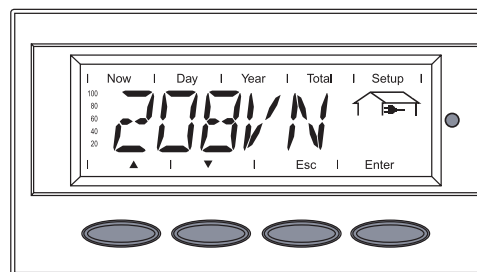
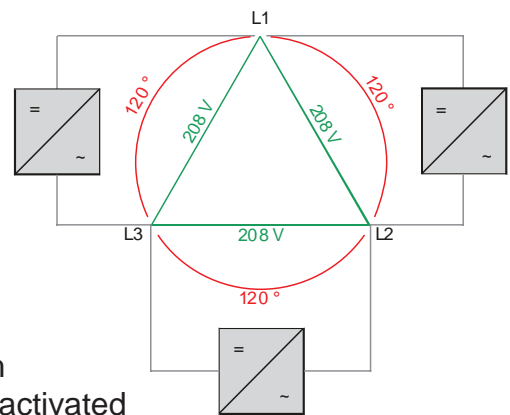

Grid voltage 208 V Delta: 120 V WYE
Neutral conductor available in the system
Neutral conductor monitoring is activated

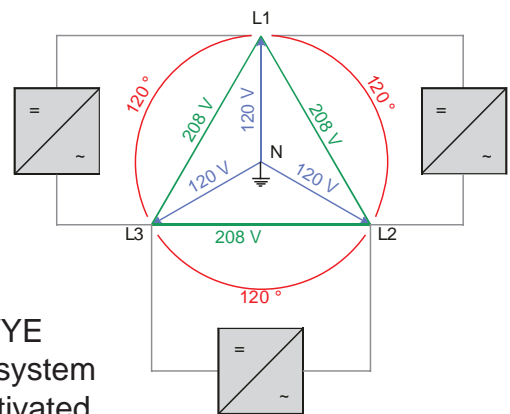

Selecting the public grid
(continued)

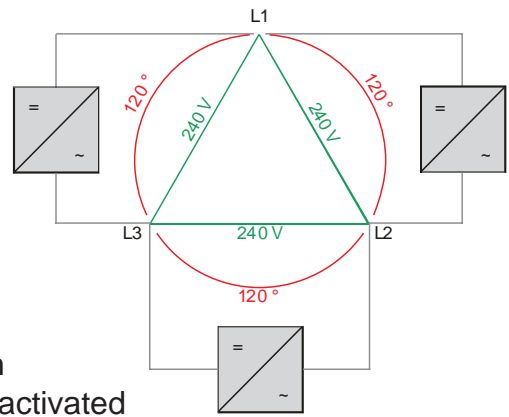
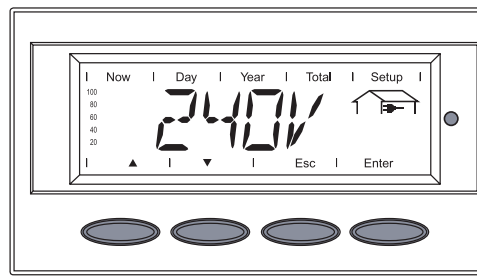

Grid voltage 240 V Delta
No neutral conductor in the system
Neutral conductor monitoring is deactivated

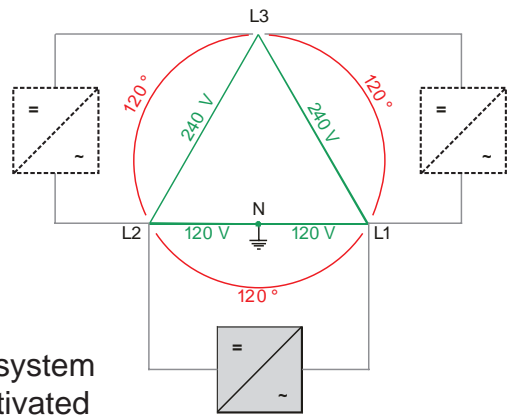
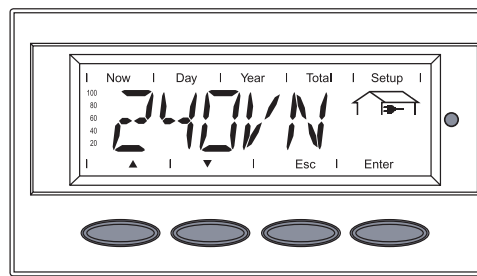
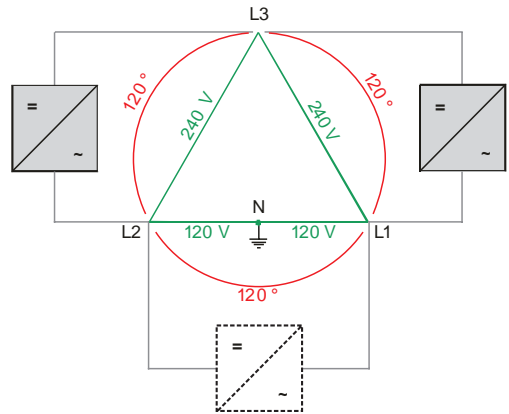

Grid voltage 240 V: 120 V Stinger
Neutral conductor available in the system
Neutral conductor monitoring is activated

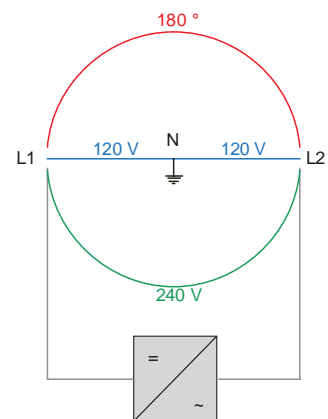

Grid voltage 240 V: 120 V Split Phase
Neutral conductor available in the system
Neutral conductor monitoring is activated

Selecting the Public grid
(continued)

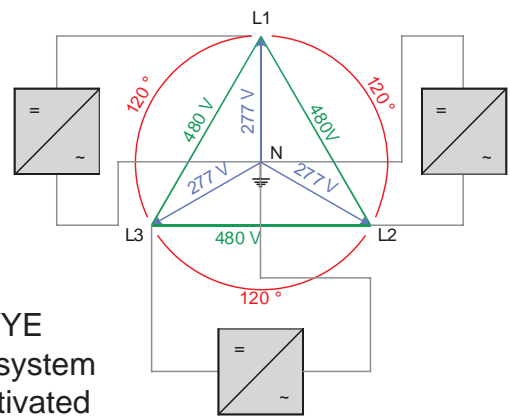
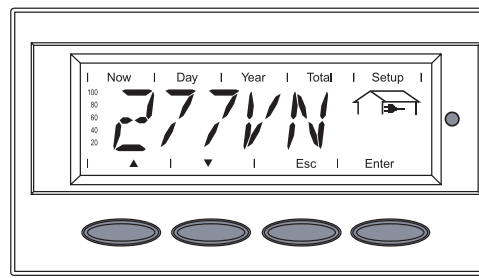

Grid voltage 480 V Delta: 277 V WYE
Neutral conductor available in the system
Neutral conductor monitoring is activated

2. Press the 'Enter' key 2x to confirm your grid selection (or use the 'Esc' key to return to grid selection)

The startup phase starts again with the segment test.

Startup Phase at Startup Operation

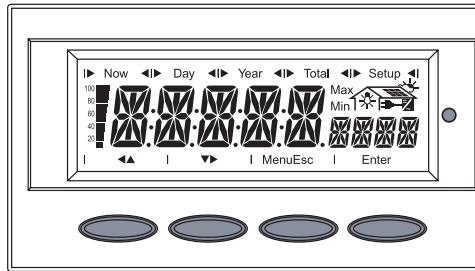

- Segment test
All display elements light up for about one second
- The Fronius IG Plus unit goes through a master check list for several seconds

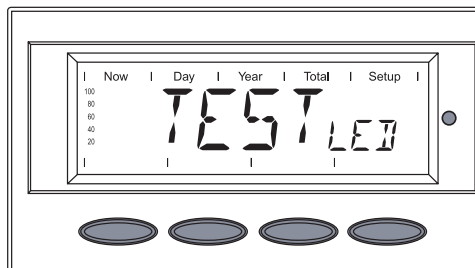

The display shows 'TEST' and indicates the respective component which is being tested (for example 'LED')

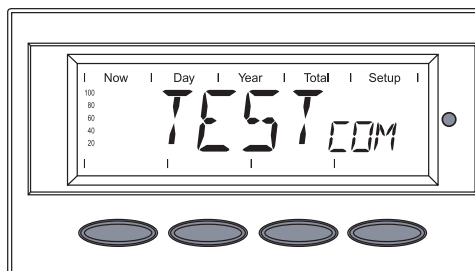

- 'TESTCOM' is shown

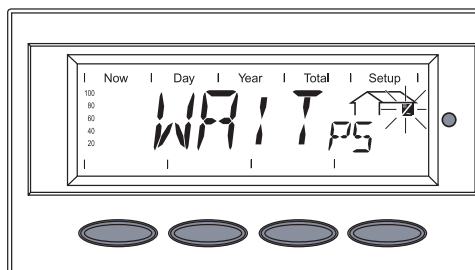

- Synchronization with grid
'WAITPS' is shown: The Fronius IG Plus is waiting for all power supplies in the network to be on stand-by. This procedure takes place dependent on the DC-voltage.

Startup Phase at Startup Operation (continued)

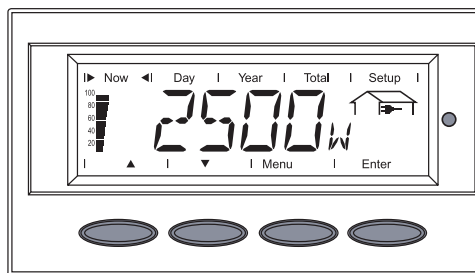
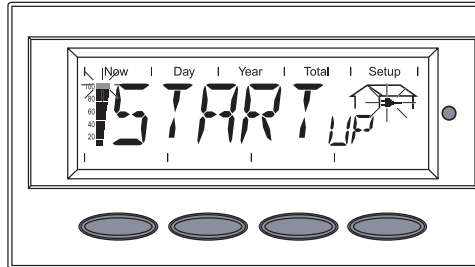
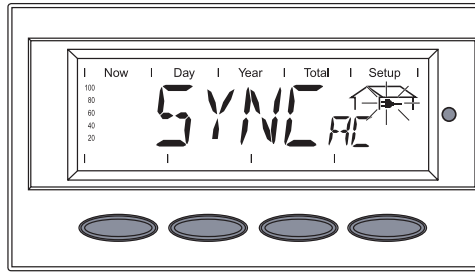

Next, the display shows 'SYNCAc', the grid icon blinks

- Startup test
Before the Fronius IG Plus unit starts feeding energy into the grid, the conditions of the grid are tested in detail in accordance with regulations. The display shows 'STARTUP'
- Operation of feeding energy into the grid
After conclusion of the tests, the Fronius IG Plus unit starts feeding energy into the grid. The display shows the present power feeding into the grid. The Operating Status LED lights up green, and the Fronius IG Plus unit starts operating.

Important For more information about the startup phase, please see chapter 'Operation', section 'Product Description Fronius IG Plus' (Startup Phase, Test Procedure).

Inserting Option Cards

Suitable Option Cards

There are several options and system upgrades available for the Fronius IG Plus, e.g.:

- Datalogger and modem interface, Ethernet/Internet connection (for using a PC to record and manage data from your photovoltaic system)
- Various large displays (Fronius Public Display)
- Sensors (temperature / irradiance / energy meter, wind speed)
- Fronius Personal Display

System upgrades are available as plug-in cards and as external boxes. The Fronius IG Plus 12.0-3 WYE 277 is designed for three option cards, all other Fronius IG Plus products are designed for two option cards.

Safety



WARNING! An electrical shock can be fatal. Danger from grid voltage and DC voltage from solar modules.

- The connection area should only be opened by a licensed electrician.
- Never work with live wires! Prior to all connection work, make sure that the AC and DC wires are not charged.
- All electrical installations must be in accordance with the National Electrical Code, ANSI/NFPA 70, and any other codes and regulations applicable to the installation site.
- For installations in Canada the installations must be done in accordance with applicable Canadian standards.



WARNING! An electrical shock can be fatal. Danger from residual voltage from capacitors.

You must wait until the capacitors have discharged. Discharge takes 5 minutes.



NOTE

Follow general ESD precautions when handling option cards.

Opening the Fronius IG Plus

When adding option cards to the Fronius IG Plus, please follow all inverter safety instructions and information.

Opening Fronius IG Plus (continued)

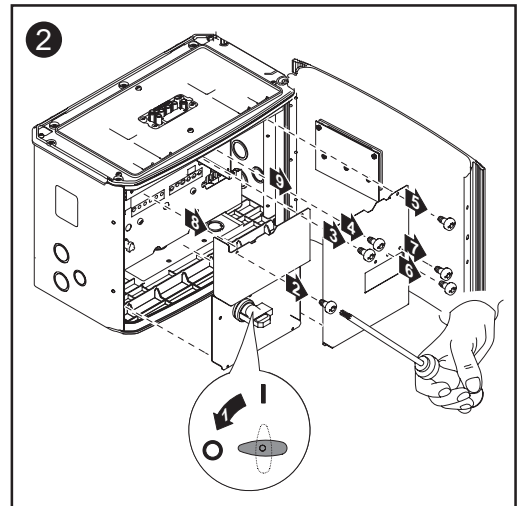
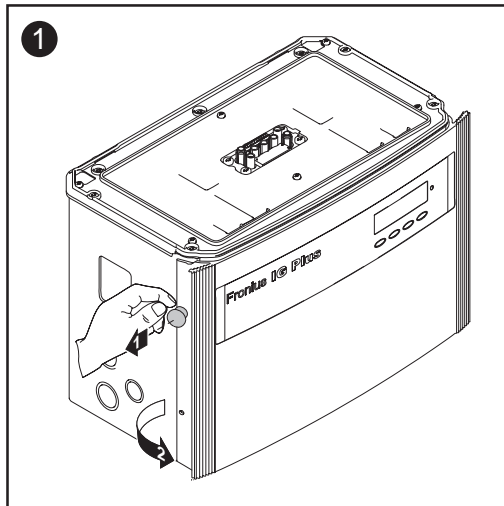

Important The plastic dividers are used to separate the data communication wires from the AC and DC wires:

- Data communication wires must be laid above the plastic dividers
- AC and DC wires are laid under the plastic dividers

Make sure that the plastic dividers are present.

Inserting Option Cards

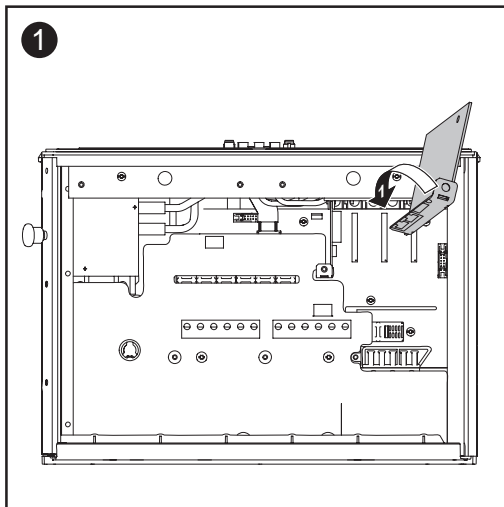

Insert option cards into free slots.

Connecting Option Cards, Laying Data Communication Wires



CAUTION! Danger of short circuit by loose metal parts from knockouts. Loose metal parts in the inverter may cause short circuits when the inverter is powered up. When removing knockouts, make sure that

- no loose metal parts fall into the inverter
- any metal pieces that do fall into the inverter are removed immediately

**Connecting
Option Cards,
Laying Data
Communication Wires**
(continued)



NOTE The knockout for the data communication wire must be above the plastic dividers so that the plastic dividers are always under the data communication wire.

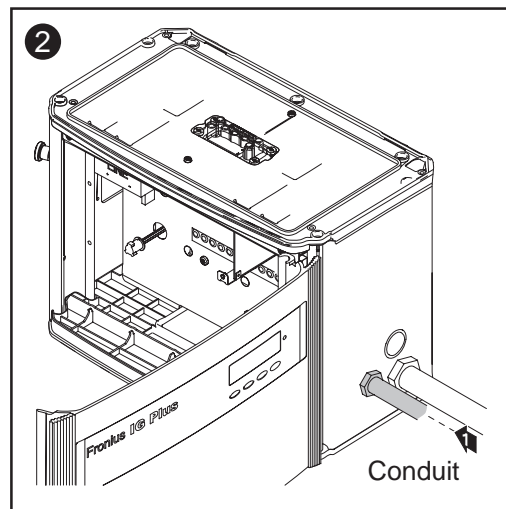
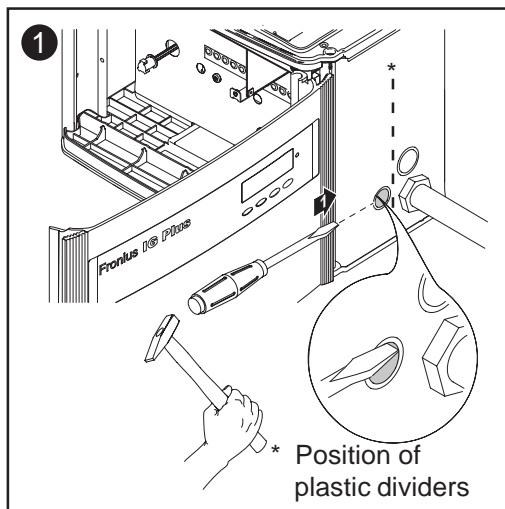

NOTE Only use water tight conduit fittings and conduits. Conduit fittings and conduits are not part of the scope of delivery for the inverter.

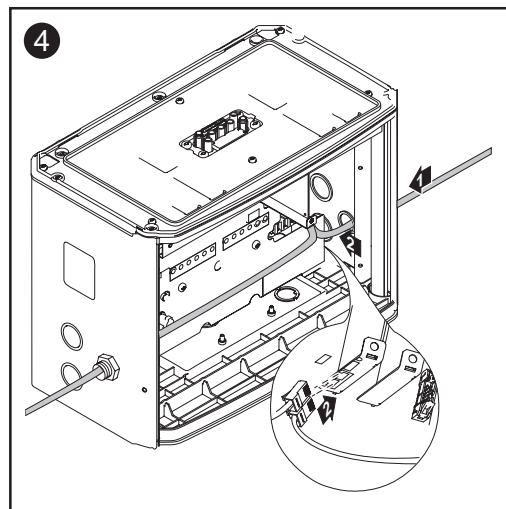
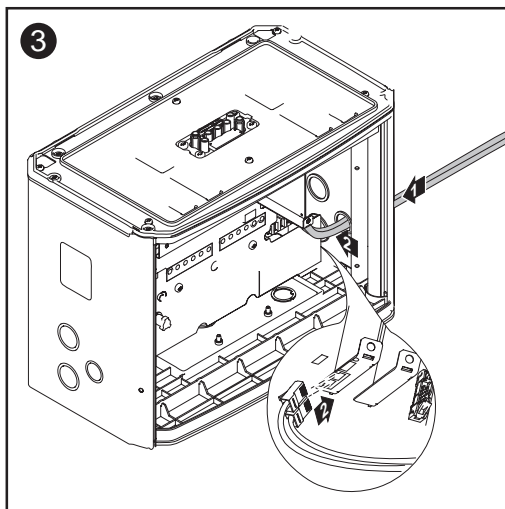

3 = one wire input for both data communication wires

4 = separated wire inputs on opposite sides (e.g. when several inverters are installed next to each other)

Closing the Fronius IG Plus

Important Secure newly-added option cards to the metal cover using the screws provided with the option cards.

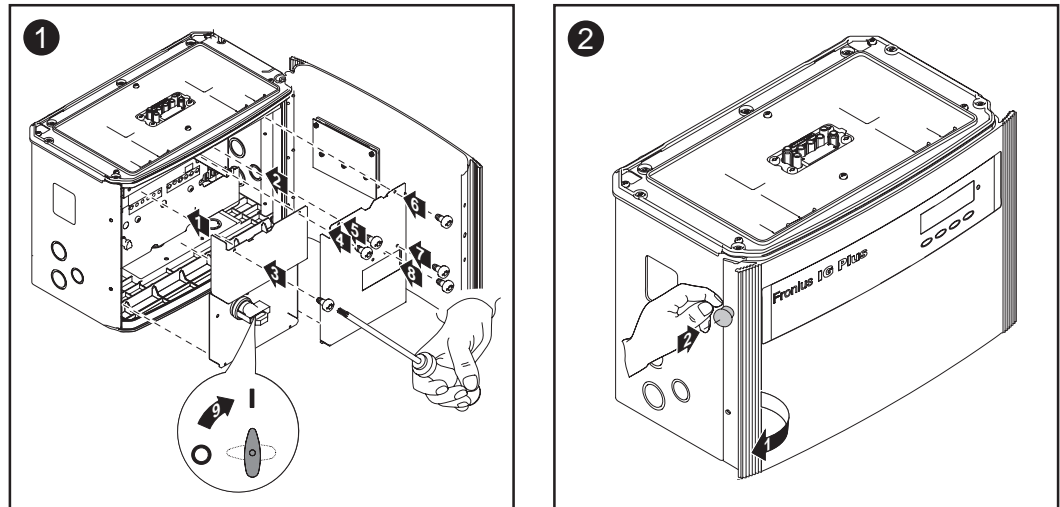

Solar Net and Data Interface

Fronius developed Solar Net to make these add-on system components flexible and capable of being used in a wide variety of different applications. Solar Net is a data network which enables several Fronius IG Plus units to be linked with the system upgrades.

Solar Net is a bus system. A single wire is all that is required for one or more Fronius IG Plus units to communicate with all system upgrade components.

The core of the Solar Net is the Datalogger. It coordinates data transmission and ensures quick and safe distribution and storage of large volumes of data.

The 'Fronius Com Card' is required to integrate the Fronius IG Plus into the Solar Net.

Important Every Fronius IG Plus that is to be monitored using a Datalogger requires a 'Fronius Com Card.' In this case, the 'Fronius Com Card' serves as a link between the internal network of the Fronius IG Plus and the Solar Net interface of the Datalogger.

Important Each inverter can only have one 'Fronius Com Card.' A network may only contain one Datalogger.

The first Fronius IG Plus with a 'Fronius Com Card' can be up to 3280 ft (1000 m) away from the last Fronius IG Plus with a 'Fronius Com Card'.

Different system upgrades are detected automatically by Solar Net.

In order to distinguish between several identical system upgrades, each one must be assigned a unique number.

Solar Net and Data Interface (continued)

In order to uniquely define each Fronius IG Plus in Solar Net, each Fronius IG Plus must also be assigned an individual number. You can assign individual numbers as per 'The Setup Menu' section in this manual.

More detailed information on the individual system upgrades can be found in the relevant operating instructions or on the Internet at <http://www.fronius-usa.com>.

Example

Logging and archiving data from the inverter and sensor using a Datalogger and sensor box.

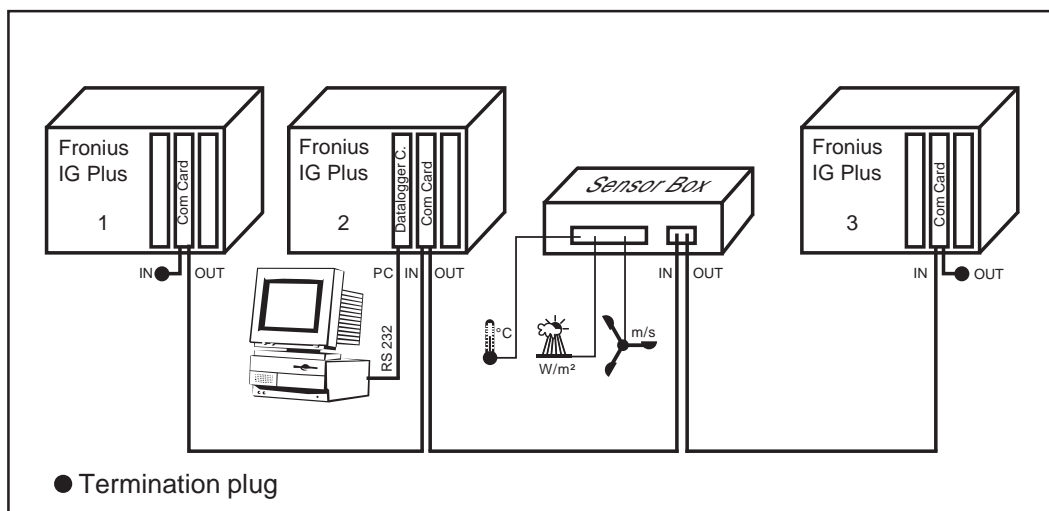

Data network with 3 Fronius IG Plus units and one sensor box:

- all Fronius IG Plus units have one 'Fronius Com Card'
- one Fronius IG Plus has a 'Datalogger card' (no. 2)
- Datalogger has two RS-232 interfaces for connecting to a PC and a modem

Option cards communicate within the Fronius IG Plus via its internal network. External communication (Solar Net) takes place via the 'Fronius Com Cards.' Each 'Fronius Com Card' is equipped with two RS485 interfaces - an input and an output. RJ45 plug connectors are used to connect to these cards.

Operation

Product description Fronius IG Plus

Keys and Symbols

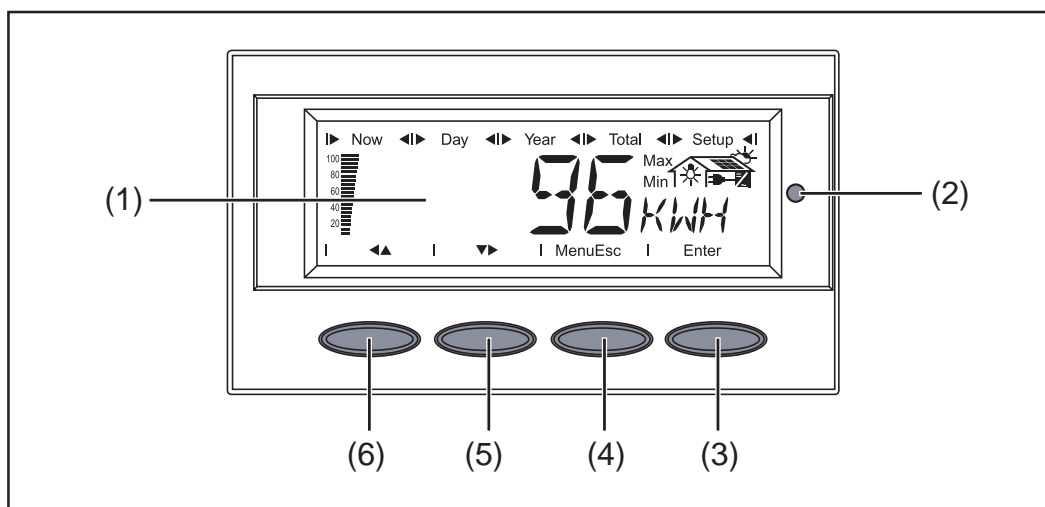

Keys and Symbols on the Fronius IG Plus

Item	Function
(1)	Display for displaying values, settings and menus
(2)	Operating Status LED for displaying the operating status
(3)	'Enter' key for confirming a choice
(4)	'Menu / Esc' key switching to the menu level ('Menu') or exit from the setup menu ('Esc')
(5)	'Down/Right' key depending on the selection: for navigating down for navigating right
(6)	'Left/Up' key depending on the selection: for navigating left for navigating up

Display

Power for the display comes from the solar modules via safety-low voltage. The display is, therefore, available only during daylight hours.

Important The Fronius IG Plus display is not a calibrated measuring instrument. A slight deviation of a few percent points is intrinsic to the system. A calibrated meter is required to make calculations for the utility company.

Display
(continued)

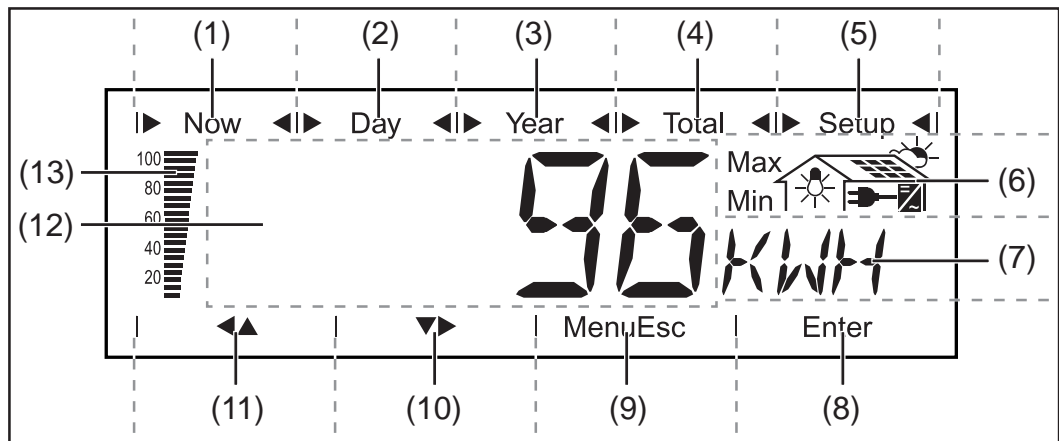

Display

Item	Function
(1)	Icons for the 'Now' display mode
(2)	Icons for the 'Day' display mode
(3)	Icons for the 'Year' display mode
(4)	Icons for the 'Total' display mode
(5)	Icons for the 'Setup' display mode
(6)	Icons for operating conditions

- | | |
|-----|------------------------------------|
| (1) | Icons for the 'Now' display mode |
| (2) | Icons for the 'Day' display mode |
| (3) | Icons for the 'Year' display mode |
| (4) | Icons for the 'Total' display mode |
| (5) | Icons for the 'Setup' display mode |
| (6) | Icons for operating conditions |

Max ... indicates the maximum value within the period of observation (depending on the display mode chosen)

Min ... indicates the minimum value within the period of observation (depending on the mode of display chosen)

Important The Min. and Max. values may not correspond to the absolute extreme values, as the measured data are recorded at two second intervals.



... appears with data readings that are transmitted by the energy meter (optional)



... appears with data readings that are directly related to the solar modules



... appears with data readings that are related to environmental conditions, like solar irradiance and temperature (optional)



... appears with AC data readings that are directly related to the grid



... appears with data readings that are related directly to the Fronius IG Plus unit

Display
(continued)

Item	Function
(7)	area for unit display for displaying the applicable measuring unit
(8)	Icon for the 'Enter' key
(9)	Icons for the 'Menu/Esc' key
(10)	Icons for the 'Down/Right' key
(11)	Icons for the 'Left/Up' key
(12)	Area for data for displaying the data value measured
(13)	output bar (not active during setup) indicates the power output fed into the grid at a given moment - independent from the display mode chosen. The screen displays % of the maximum possible output power of your solar inverter

Startup phase

After switching on automatically, the Fronius IG Plus unit goes through a self-test, followed by an extensive test of the grid. This test takes five minutes. During the startup sequence the illumination of the Operating Status LED is yellow.

Test Procedure

1. Segment test
All display elements light up for about one second

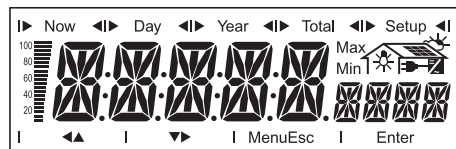

2. Self test of important components of the Fronius IG Plus unit
 - The Fronius IG Plus unit goes through a master check list for several seconds
 - The display shows 'TEST' and indicates the respective component which is being tested (for example 'LED')

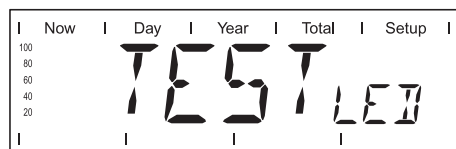

3. Synchronization with grid
 - 'WAITPS' is shown: The Fronius IG Plus is waiting for all power stage sets in the network to be on stand-by. This procedure takes place dependent on the DC-voltage.

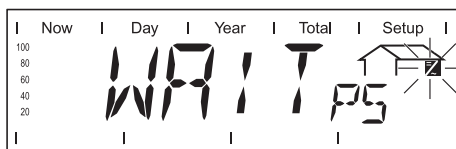

Test Procedure
(continued)

- Next, the display shows 'SYNCAc', the grid icon blinks

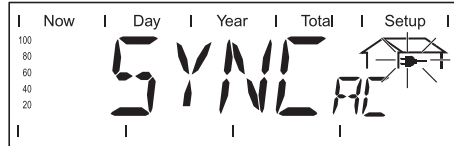

4. Startup Test

- Before the Fronius IG Plus unit starts feeding energy into the grid, the conditions of the grid are tested in detail in accordance with regulations.
- The display shows 'STARTUP'

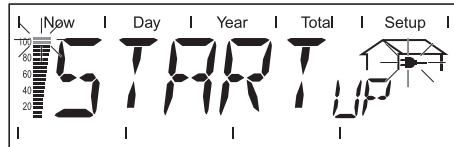

The startup test takes five minutes. The time elapsed is indicated by a bar shrinking from the top down.

Whenever two scale divisions stop flashing and disappear, 1/10 of the total duration of the test is over.

5. Operation of feeding energy into the grid

- After conclusion of the tests, the Fronius IG Plus unit starts feeding energy into the grid.
- The display shows the present power feeding into the grid
- The Operating Status LED lights up green, and the Fronius IG Plus unit starts operating



Operating Status LED

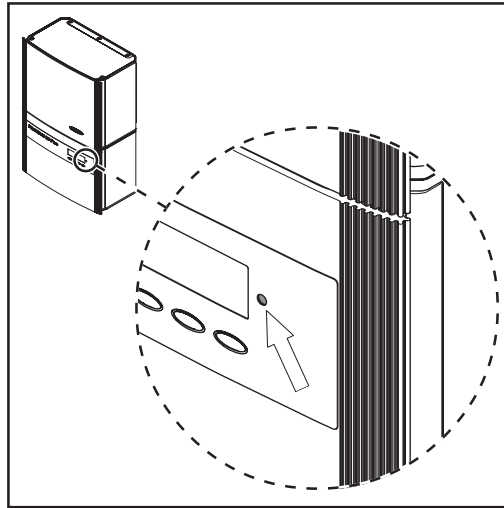

Position of Operating Status LED on the Fronius IG Plus

Depending on the operating status, the Operating Status LED assumes different colors:

Operating Status LED	Explanation
lights up green	A green light starts as soon as the Fronius IG Plus unit has completed the startup phase, and stays green as long as the operation of feeding power into the grid continues. It indicates faultless operation of the photovoltaic equipment.
flashes green	The photovoltaic equipment is operating without fault, an additional message is shown on the screen. When a status code is shown, rectify the relevant condition by going to the 'Maintenance and Service' chapter, 'Status Diagnosis and Troubleshooting' section. The status message can be acknowledged by pressing the 'Enter' key.
lights up orange	The FRONUS IG unit will enter the automatic startup-phase, as soon as the photovoltaic modules yield sufficient power output
flashes orange	when a warning is shown on the screen or the Fronius IG Plus unit has been set to standby operation in the setup menu (manual shutoff of operation). The next day, operation will resume automatically. During the time the LED flashes orange, the operation can be resumed manually at any time (see section 'The Setup Menu')

**Operating
Status LED**
(continued)

Operating Status LED	Explanation
lights up red	General status: the respective status code is shown on the screen
remains dark	There is no connection to the solar modules; no power output from modules due to darkness

A list of most status codes, the corresponding status information, their status causes and repair measures can be found in the chapter 'Troubleshooting and Maintenance', section 'Status Diagnosis and Troubleshooting'.

Operating scheme - the Display

Activating Display Illumination

1. Press any key

The display backlight is activated.

If no key is pressed for 30 seconds, the display backlight stops.
The setup menu also offers a choice between permanently lit or permanently dark display.

Accessing Menus

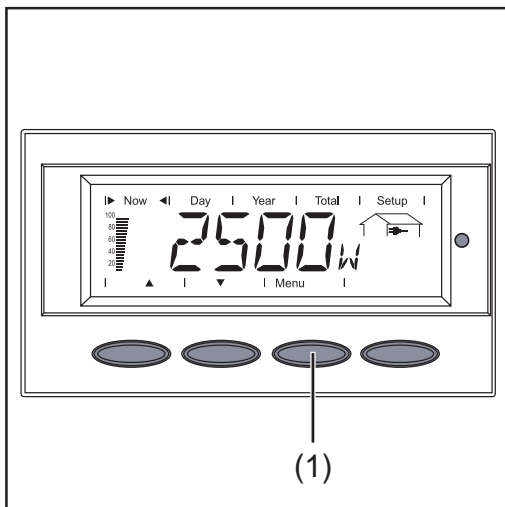

Accessing Menus

1. Press the 'Menu' button (1)

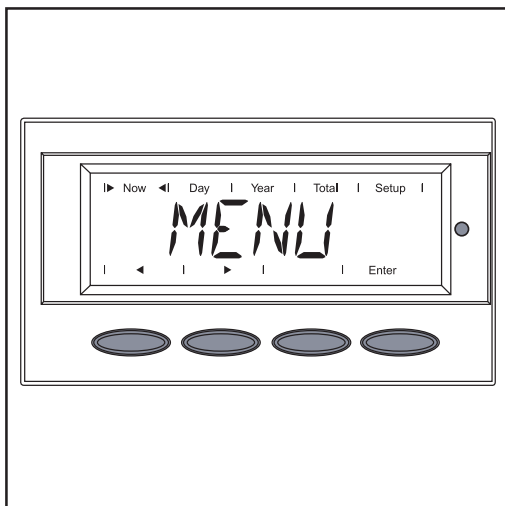

Menu Levels

'Menu' will appear on the display

The Fronius IG Plus is now in the menu level.

- From the menu level you can
- set the desired display mode
 - access the Setup menu

Selecting a display mode

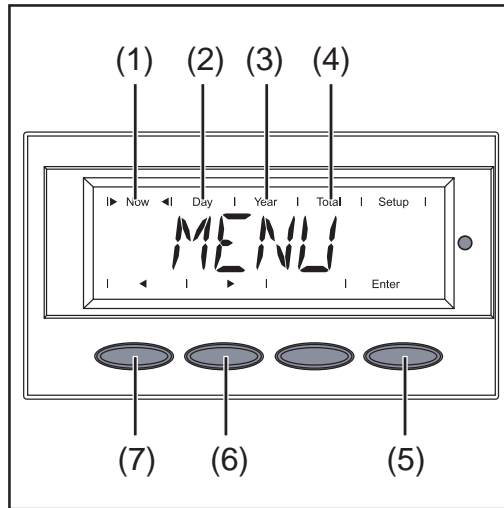

Selecting a Display Mode

1. Accessing Menu Levels
2. Use the 'left' (7) or 'right' (6) keys to select your preferred display mode (1) - (4)
3. Press 'Enter' (5)

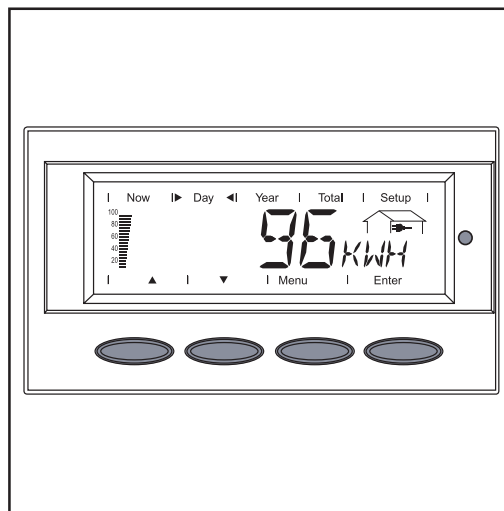

Example: 'Day' display mode

The selected display mode is shown

Important The 'Year' menu option is supported only when the optional Datalogger is connected. This system upgrade includes a real-time clock.

Scrolling Between Display functions

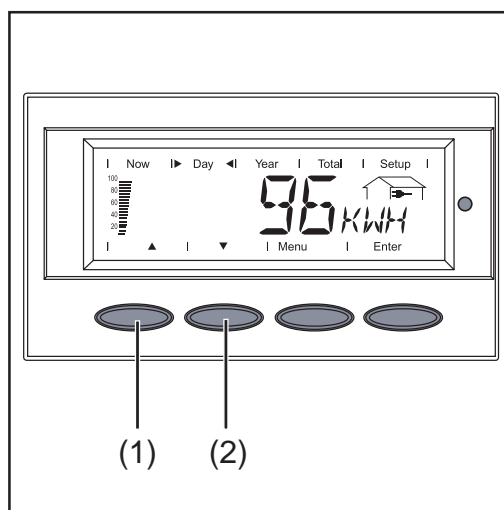



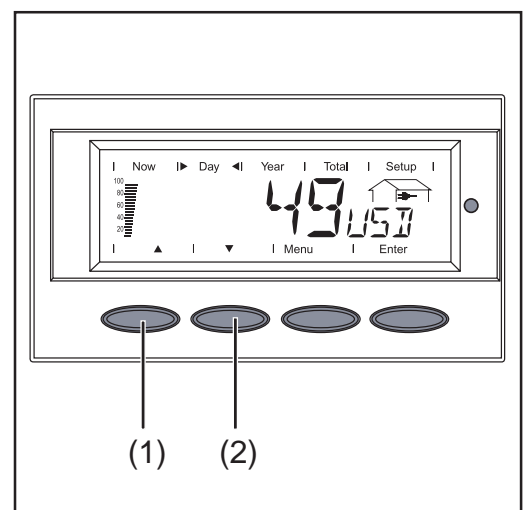





















Example: 'Fed-in Energy' display value



Example: 'Earnings' display value

1. Selecting a desired display mode
2. Scroll through the available display values using the 'Up' (1) and 'Down' (2) keys

Overview of Display Values

Display mode	Icon	Unit	Optional	Display value
'Now'		W	-	output power
		V	-	grid voltage
		A	-	output current
		Hz	-	grid frequency
		V	-	module voltage
		A	-	module current
		°F / °C	x	module temperature
		-	-	GFDI status
		W	x	output reading of building load meter
		° F / ° C	x	ambient temperature
		W/m ²	x	irradiance
		HH:MM	x	time
'Day'		kWh / MWh	-	energy supplied
		currency	-	yield
'Year'		kg / T	-	CO ₂ reduction
'Total'		W	-	maximum power output
		V	-	maximum grid voltage
		V	-	minimum grid voltage
		V	-	maximum array voltage
		kwh / MWh	x	energy as read by building load meter
		° F / ° C	x	maximum module temperature
		° F / ° C	x	minimum module temperature
		° F / ° C	x	maximum ambient temperature
		° F / ° C	x	minimum ambient temperature
		W/m ²	x	maximum irradiance
		HH:MM	-	operating hours of Fronius IG Plus unit

x optional

When the DatCom component for the required option is not available, the message 'N.A.' (not available) is shown.

Display Modes

Display Modes The following display modes are available for the Fronius IG Plus:

Display mode 'Now' shows present data

Display mode 'Day' shows data for the present day

Display mode 'Year' shows data for present calendar year - only available in combination with optional Datalogger

Display mode 'Total' shows data since your Fronius IG Plus unit first started operating

Overview The 'display modes' are composed of the following sections:

- Within display mode 'Now' displayed data
- Within display modes 'Day / Year / Total' displayed data

Within display mode 'Now' displayed data

Selecting display mode 'Now'

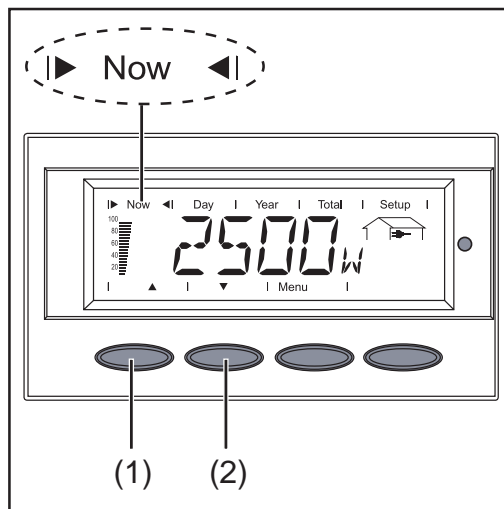

First display values in the 'Now' display mode

1. Select display mode 'Now'

The first display value appears in the 'Now' display mode

2. Use the 'Down' (2) key to scroll to the next display value

Scroll back using the 'Up' key (1)

Within display mode 'Now' displayed data



AC power supplied

power supplied to grid at the particular moment (Watts)

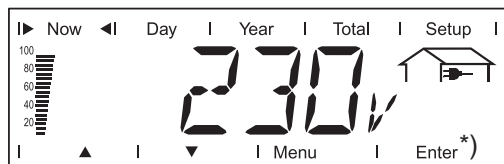

AC grid voltage

(Volts)

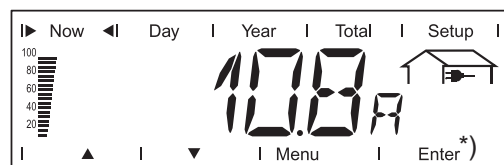

AC current supplied

current supplied to the grid at the particular moment (Amperes)

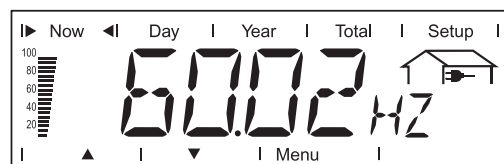

Grid frequency

(Hertz)

*) only for a multi-phase Fronius IG Plus

Within display mode 'Now' displayed data
(continued)

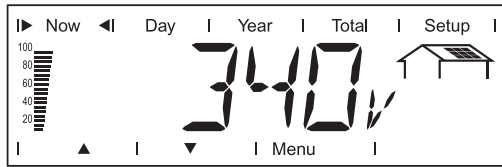

DC array voltage

voltage of the solar array at the moment of data display (Volts)

The voltage shown while AC power is supplied is called MPP voltage (MPP = maximum power point).

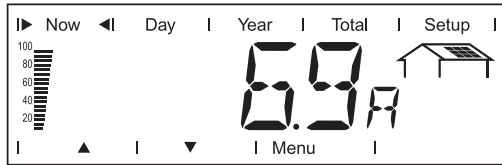

DC array current

current supplied by solar array at the moment of data display (Amperes)

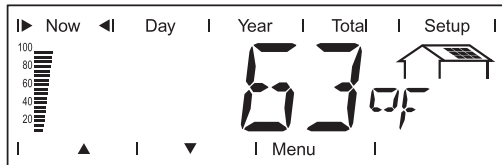

Module temperature (optional)

temperature at solar modules (°F; can also be set for °C; this corresponds to temperature sensor No.1; Sensor Box, Datalogger and temperature sensor required)

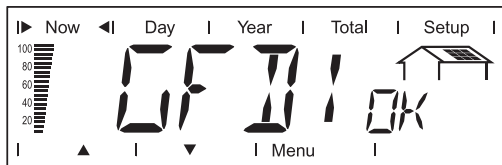

GFDI-Status

if there is no ground fault in the system, 'OK GFDI' is shown

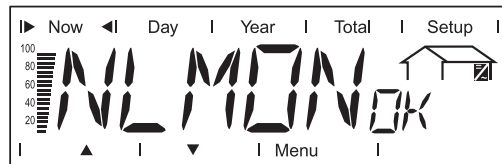

NL-MON Communication

When the communication with the plug-in card 'NL-MON' sustains 'NLMONOK' is shown.

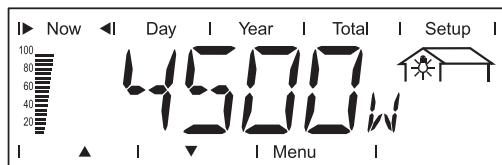

Power drawn from the grid (optional)

present consumption (Watts; Sensor Box, Datalogger and load sensor required)

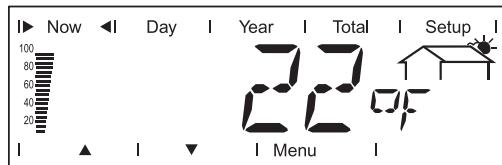

Ambient temperature (optional)

(° F; can also be set for ° C in setup menu; this corresponds to temperature sensor No.2; Sensor Box, Datalogger and temperature sensor required)

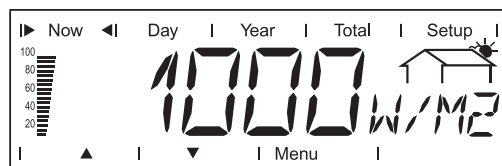

Irradiance (optional)

the sunlight's power per square meter (Watts/m²; Sensor Box and irradiance sensor required)

Within display mode 'Now' displayed data
(continued)

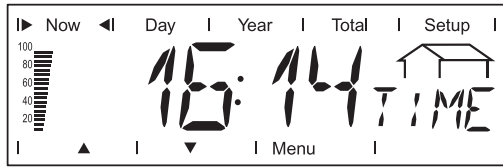

Time of the day (optional data-logger)

When the time on the Fronius IG Plus or a system upgrade is changed, this changes the time on all connected devices via Solar Net.

Options

If the DatCom component for the required options are not available, the message "N.A." (not available) is shown.

Within display modes 'Day / Year / Total' displayed data

General

For the Fronius IG Plus unit, the day begins when it switches on. If the DC supply line is disconnected, the following parameters within the display mode 'Day' will be re-set after repeating the start-up:

- yield (currency can be selected)
- CO₂ reduction (lbs.)
- maximum power supplied (Watts)
- maximum grid voltage (Volts)
- minimum grid voltage (Volts)
- energy supplied (kWh)
- operating hours for Fronius IG Plus unit

If an optional datalogger is available, the display values listed always apply for the whole day.

Selecting display modes 'Day / Year / Total'

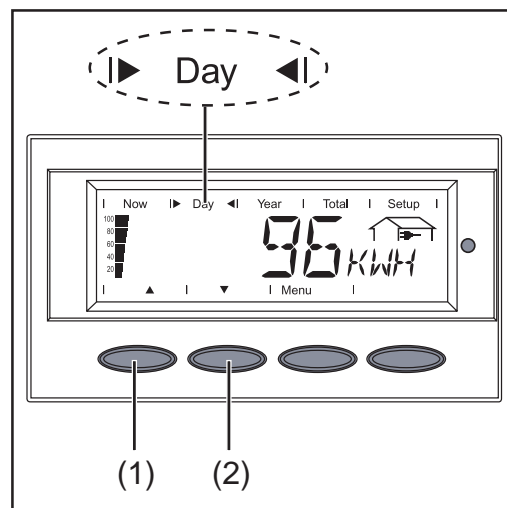

First display value in the display mode 'Day'

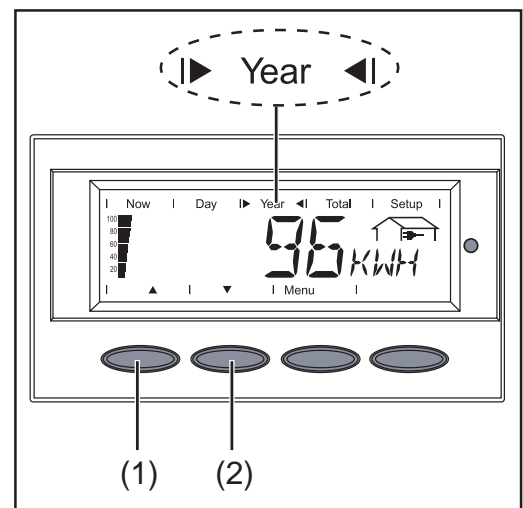

First display value in the display mode 'Year'

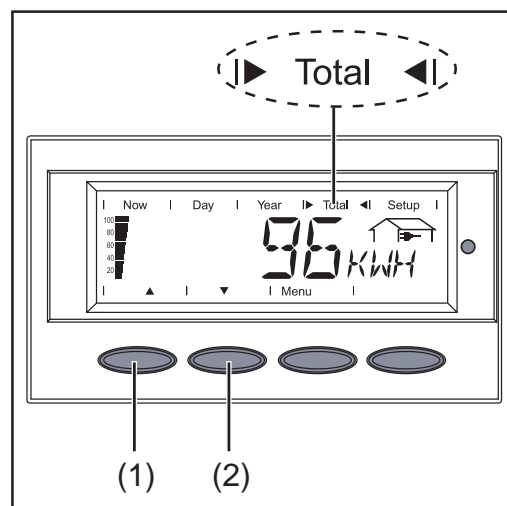

First display value in the display mode 'Total'

1. Select display mode 'Day' or 'Year' or 'Total'

The first display value in the selected display mode is shown.

2. Use the 'Down' (2) key to scroll to the next display value

Scroll back using the 'Up' key (1)

Within display modes 'Day / Year / Total' displayed data

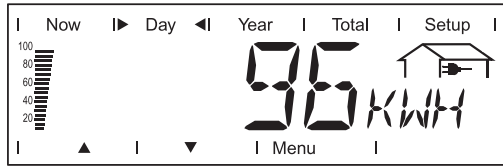

Energy supplied

energy supplied during monitored period (kWh / MWh)

Due to the variety of different monitoring systems, there can be deviations between the readings of other metering instruments as compared to the readings from the Fronius IG Plus. For determining the energy supplied to the grid, only the readings of the calibrated meter supplied by the electric utility company are relevant.

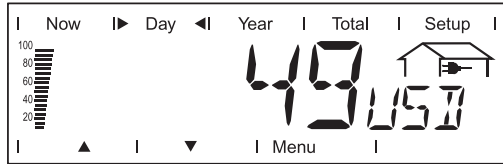

Yield

money earned during monitored period (set currency and price per kWh in setup menu)

As was the case for the energy supplied, readings may differ from those of other instruments.

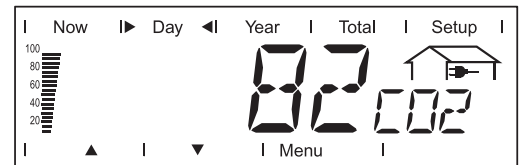
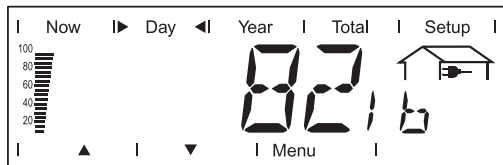

CO₂ reduction

CO₂ emissions avoided during monitored period (lb / T); T = tons
The area for unit display switches between 'lb' and 'CO2'.

The CO₂ meter gives an indication of CO₂ emissions (in lb/t) that would be released during the generation of the same amount of electricity in a combustion power plant.

This is set for 1.3 lb/kWh in the factory.



Maximum output power

highest output power of the Fronius IG Plus during observation period (Watts)

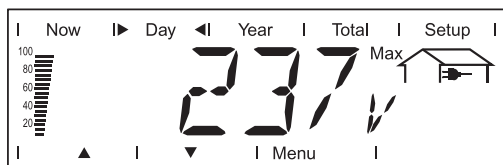

Maximum grid voltage

highest reading of grid voltage (V) during observation period

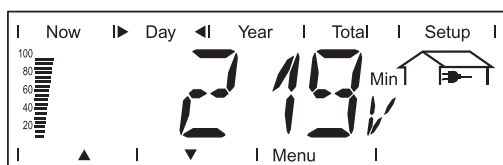

Minimum grid voltage

lowest reading of grid voltage (V) during observation period

Within display modes 'Day / Year / Total' displayed data (continued)

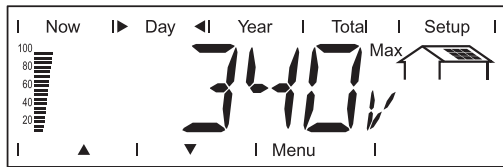

Maximum array voltage
highest reading of array voltage (V) during observation period

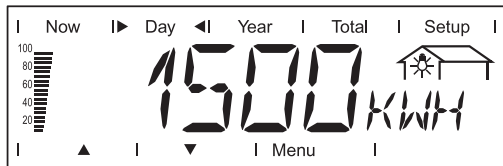

Energy consumption meter reading (optional)
energy consumed during observation period (kWh / MWh; Sensor Box, Datalogger and consumption sensor required)

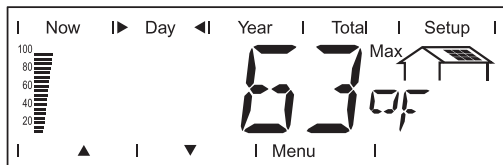

Maximum module temperature (optional)
highest temperature reading at solar modules during observation period (°F; can also be set for °C in setup menu; temperature sensor No. 1, , Datalogger and Sensor Box required)

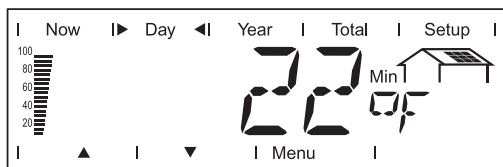

Minimum module temperature (optional)
lowest temperature reading at solar modules during observation period (°F; can also be set for °C in setup menu; temperature sensor No. 1, Datalogger and Sensor Box required)

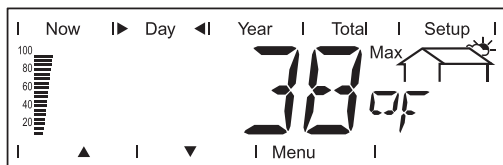

Maximum ambient temperature (optional)
highest ambient temperature reading during observation period (°F; can also be set for °C in setup menu; temperature sensor No. 2, Datalogger and Sensor Box required)

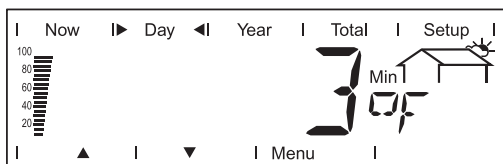

Minimum ambient temperature (optional)
lowest ambient temperature reading during observation period (°F; can also be set for °C in setup menu; temperature sensor No 2, Datalogger and Sensor Box required)

Within display modes 'Day / Year / Total' displayed data
(continued)

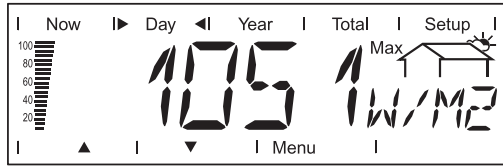

Maximum irradiance (optional)
highest irradiance during observation period (W/m²; Sensor Box and reference cell required)

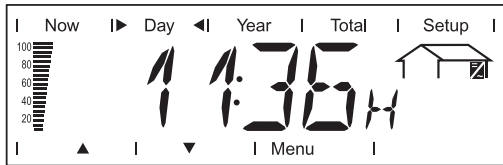

operating hours
duration of operation of Fronius IG Plus unit (HH:MM)

Duration of operation is shown in hours and minutes up to 999 h and 59 min (display: "999:59"). From then on only full hours are displayed.

Although the Fronius IG Plus unit does not operate during the night, all sensor data are recorded around the clock.

Options

If the DatCom component for the required options are not available, the message "N.A." (not available) is shown.

The Setup Menu

Default Settings

The Fronius IG Plus unit is designed for fully automatic operation. No manual control is necessary for feeding the power it generates into the grid.

The setup menu allows easy readjustment of the Fronius IG Plus's preset parameters to your needs.

Enter the setup menu

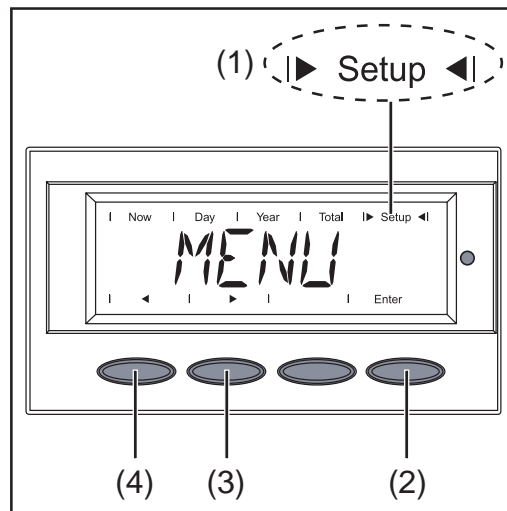

'Setup' mode selected in the menu level

1. Switch to the menu level (press the 'Menu' key)
2. Select the 'Setup' (1) mode using the 'Left' (4) or 'Right' (3) keys
3. Press 'Enter' (2)

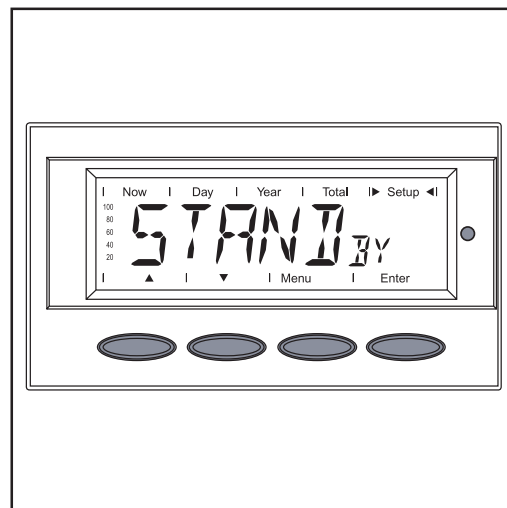

Menu item 'STANDBY'

The Setup Menu's first menu item 'STANDBY' is shown.

Scrolling among menu items

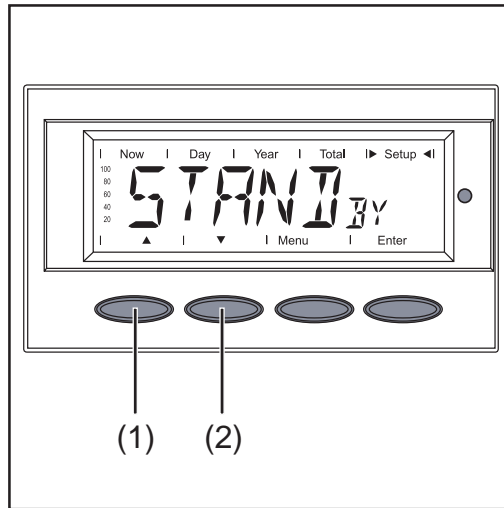

Example: menu item 'STANDBY'

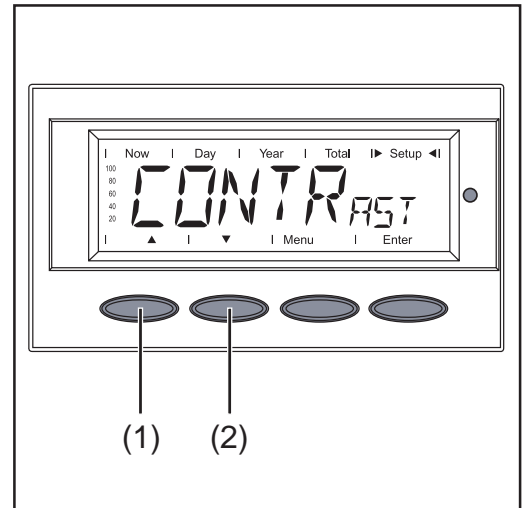

Example: menu item 'CONTRAST'

1. Open the setup menu
2. Scroll through the available menu items using the 'Up' (1) and 'Down' (2) keys

Menu Items in the Setup Menu

STANDBY

Manual activation / deactivation of Standby operation using the 'Enter' key

Unit -
 Setting range Enter
 Factory setting 'Standby' deactivated

- During standby operation the electronic system of the power stage is switched off. No power is fed into the grid.
- The Operating status LED flashes orange.
- The orange flashing Operating Status LED stops at dusk.
- After the subsequent sunrise, the power supply operation into the grid is resumed automatically (after completion of the startup phase the LED is illuminated green).
- Grid supply operation can be resumed at any time whenever the LED is flashing orange (deactivate 'STANDBY')

CONTRAST

set contrast on LCD display

Unit -
 Setting range 0 - 7
 Factory setting 7

Since contrast depends on temperature, it may be necessary to adjust the menu item 'Contrast' when ambient conditions change

**Menu Items in
the Setup
Menu**
(continued)

LIGHT_{MODE}

pre-setting of display illumination.

Unit -
Setting range AUTO / ON / OFF
Factory setting AUTO

AUTO: The display illumination will stop 30 seconds after the last time a key has been pressed

ON: The display will remain illuminated whenever power is supplied to the grid

OFF: The display illumination will be permanently off.

Important These instructions are only applicable for the display background illumination. The LCD display will still remain on during operation. Its energy consumption is less than one mW (1/1000 W).

CASH

setting of currency and rate for invoicing the energy supplied

Unit -
Display area Currency / Charge rate/kWh
Factory setting USD

CO₂

setting of CO₂ reduction factor

Unit lb/kWh or T/kWh
Display area 00.01 - 99.99
Factory setting 1.3 lb/kWh

YIELD

setting of

- an OFF_{SET} value for the Total energy display
- a measurement correction value for the Day, Year and Total energy display

Unit -
Display area OFF_{SET} / CALI.
Factory setting -

OFF_{SET} Preset value for the energy supplied, added to the actual energy supplied (e.g. transfer value at the exchange of the inverter)
Display area: 5 digits + SI prefix (k..., M...)

CALI. Preset correction value, so that the data shown on the inverter display corresponds to the calibrated data shown on the electric meter
Display area: -5.0 - +5.0 % in steps of 0.1

**Menu Items in
the Setup
Menu**
(continued)

IG-NR

Setting the number (address) of the Fronius IG Plus unit in a setup comprising multiple Fronius IG Plus units linked together

Unit	-
Setting range	01 - 99 (100. Fronius IG Plus = 00)
Factory setting	01

Important Allocate a different address to each Fronius IG Plus when connecting several Fronius IG Plus into a data communication network using the 'Fronius Com Card' and a Datalogger.

DATCOM

indicates status of data transmission, resets the Personal Display Card and Interface Card

Unit	-
Setting range	Displays OK _{COM} ; PDCD _{RST} / IFCD _{RST}
Factory setting	-

TIME

setting of date and time

Unit	DDMMYYYY, HH:MM
Display area	Date / Time
Factory setting	-

The menu item 'Time' is only supported when the Fronius Datalogger is installed.

STATEPS

Status display of power stage sets; the last error that has occurred can be displayed

Important State 306 (Power Low) and 307 (DC-Low) appear naturally every morning and evening due to low solar irradiance. These status messages are not the result of a fault.

VERSION

displays version number of the IG-Brain and the power stage sets

Unit	-
Setting range	MAIN _{CTRL} / LCD / PS (PS00, PS01, PS02)
Factory setting	-

Setting and Displaying Menu Items

Menu Items Settings - General

1. Open the setup menu
2. Select the desired menu item
3. Press the 'Enter' key
4. Use the 'Up' and 'Down' keys to change the value of the menu item
5. Press the 'Enter' key - the changed value is saved in the menu item
6. Press the 'Esc' key to exit the menu item

Setting Menu Item 'STANDBY'

Activate 'STANDBY' - manual shut off of operation

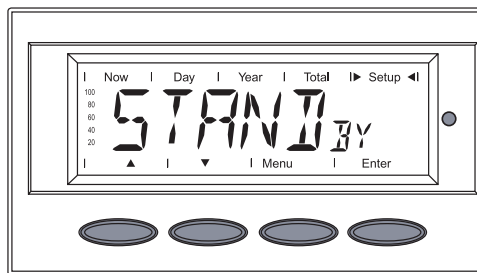

1. Select the menu item 'STANDBY'
2. Press the 'Enter' key

The standby mode is activated

The Operating Status LED
flashes orange.

The display switches between
...

'STANDBY' and

'ENTER'

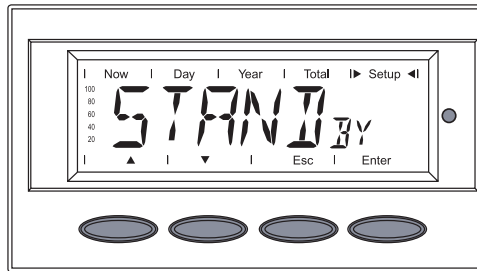

3. Press the 'Esc' to exit the menu
item 'STANDBY'

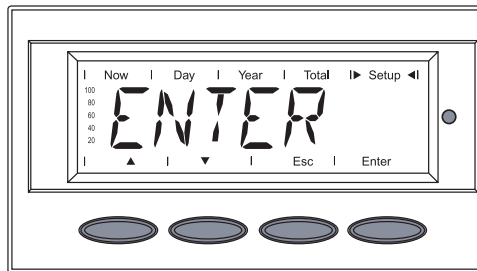

Restoring the grid feed:

1. Select the menu item 'STANDBY'
2. Press the 'Enter' key

The Fronius IG Plus will switch to the Startup phase.

After a successful startup, the Operating Status LED will be green.
The present power feed will be displayed.

**Setting menu item
'CONTRAST'**

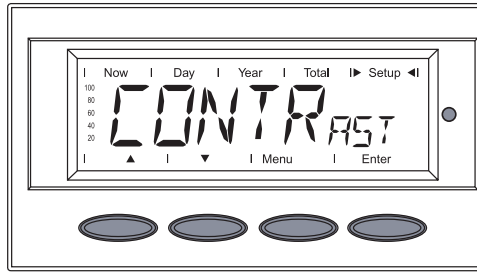

1. Select menu item 'CONTRAST'
2. Press the 'Enter' key

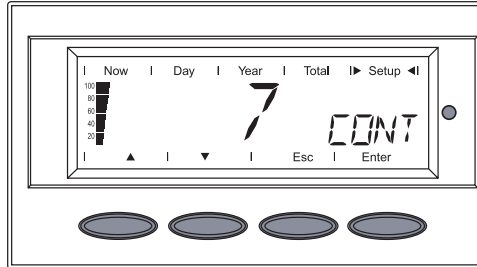

Setting '7' for maximum possible contrast is shown

3. Use the 'Up' and 'Down' keys to select the desired level of contrast
▲ ▼

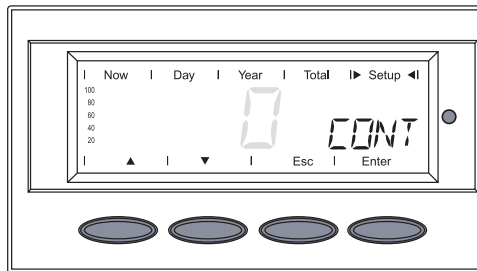
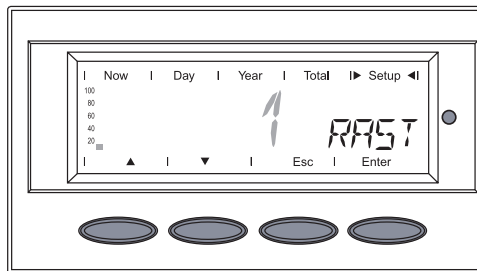

setting '0' for the minimum possible contrast

4. Press the 'Enter' key to accept the setting
5. Press the 'Esc' key to exit menu item 'CONTRAST' or to maintain previous setting

**Setting menu item
'LIGHTMODE'**



1. Select menu item 'LIGHTMODE'
2. Press the 'Enter' key

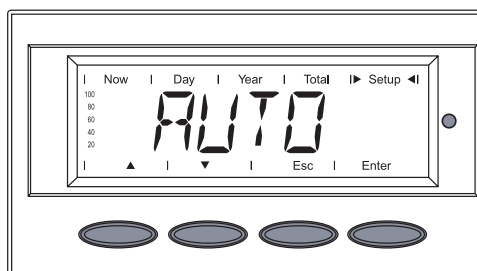

The 'AUTO' setting is shown

AUTO ... The display illumination will stop 30 seconds after the last time a key has been pressed.

Setting menu item 'LIGHTMODE'
(continued)

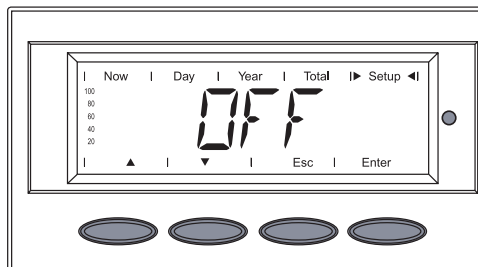
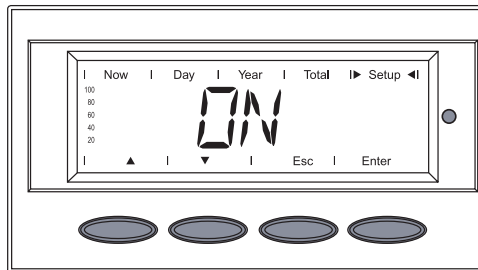

ON ... The display will continue to remain illuminated whenever power is supplied to the grid.

OFF ... The display illumination will be permanently off.

3. Use the 'Up' and 'Down' keys to select the desired setting for the display illumination
▲ ▼
4. Press the 'Enter' key to accept the setting
5. Press the 'Esc' key to exit menu item 'LIGHTMODE' or to maintain previous setting

Setting menu item 'CASH'

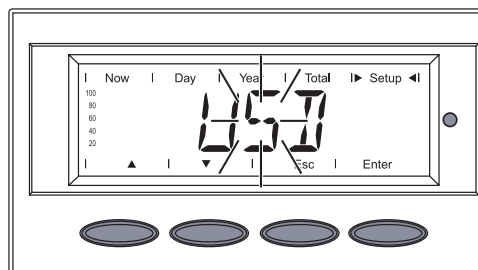
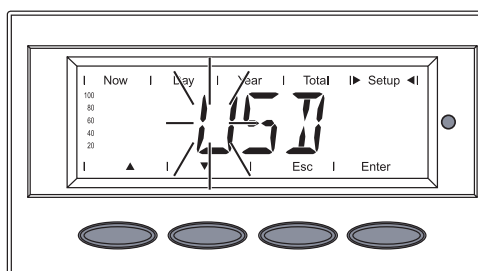
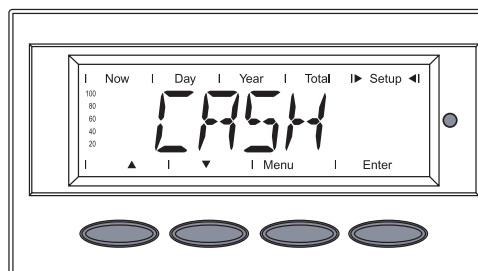

1. Select menu item 'CASH'
2. Press the 'Enter' key

The **currency** is shown
factory setting = 'USD'
The first character flashes

3. Use the 'Up' and 'Down' keys to select a letter for the first character
▲ ▼
4. Press the 'Enter' key

The second character flashes

5. Use the 'Up' and 'Down' keys to select a letter for the second character
▲ ▼
6. Press the 'Enter' key

**Setting menu
item 'CASH'**
(continued)

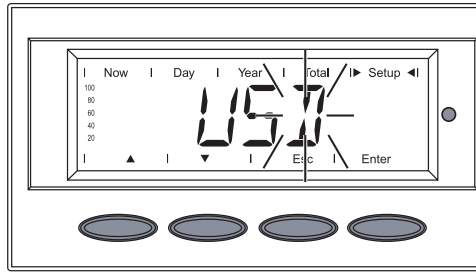

The third character flashes

7. Use the 'Up' and 'Down' keys to select a letter for the third character

▲ ▼

8. Press the 'Enter' key

The set currency flashes

9. Press the 'Enter' key

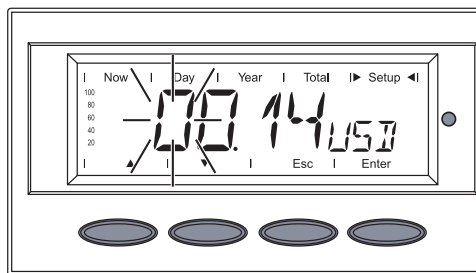
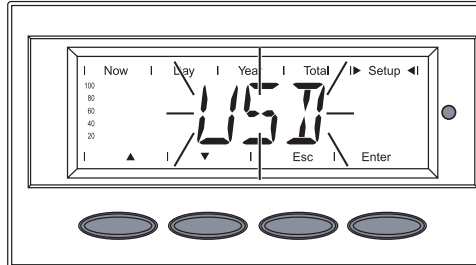

The rate for energy supplied is now displayed in kWh/currency, factory setting = 0.14 USD / kWh

The first digit flashes

10. Use the 'Up' and 'Down' keys to select a value for the first digit (e.g. 0)

▲ ▼

11. Press the 'Enter' key

The second digit flashes

12. Use the 'Up' and 'Down' keys to select a value for the second digit (e.g. 0)

▲ ▼

13. Press the 'Enter' key

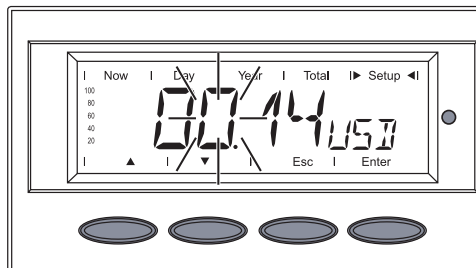

The first digit after the decimal point flashes

14. Use the 'Up' and 'Down' keys to select a value for the first digit after the decimal point (e.g. 1)

▲ ▼

15. Press the 'Enter' key

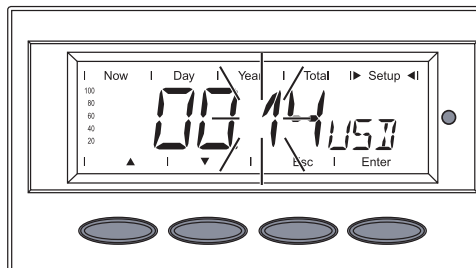

Setting menu item 'CASH'
(continued)

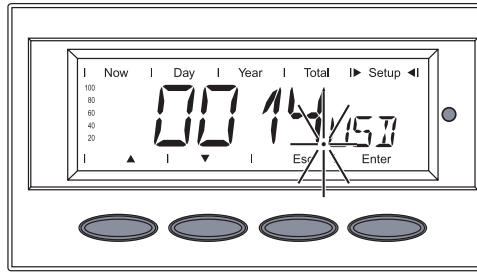

The second digit after the decimal point flashes

16. Use the 'Up' and 'Down' keys to select a value for the second digit after the decimal point (e.g. 4)
▲ ▼

The values that can be set range from 00.01 to 99.99

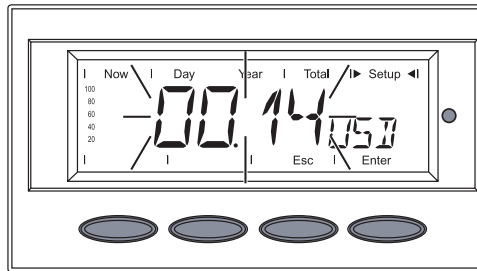

17. Press the 'Enter' key

The set rate for energy supplied flashes

18. Press the 'Enter' key

The currency and the rate for supplied energy are now accepted

19. Press the 'Esc' key to exit menu item 'CASH' or to maintain previous setting

Setting menu item 'CO₂'

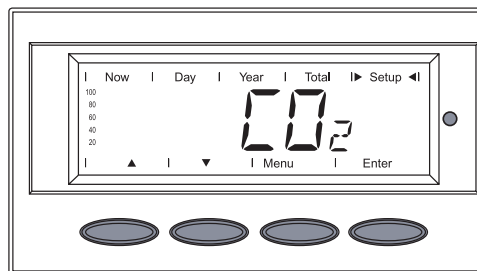

1. Select menu item 'CO₂'
2. Press the 'Enter' key

The CO₂ reduction factor is shown; the first digit flashes

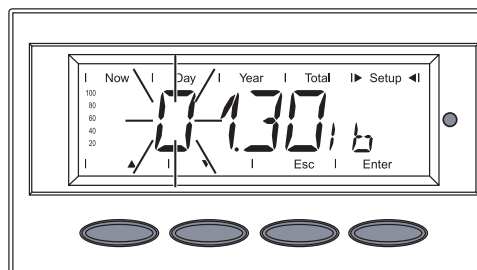

3. Use the 'Up' and 'Down' keys to select a value for the first digit
▲ ▼
4. Press the 'Enter' key

**Setting menu
item 'CO₂'
(continued)**

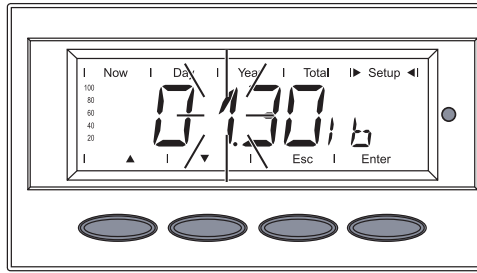

The second digit flashes

5. Use the 'Up' and 'Down' keys to select a value for the first digit
▲ ▼
6. Press the 'Enter' key

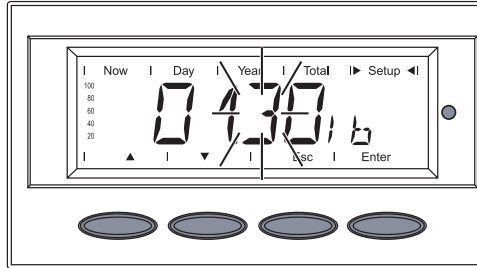

The first digit after the decimal point flashes

7. Use the 'Up' and 'Down' keys to select a value for the first digit after the decimal point
▲ ▼
8. Press the 'Enter' key

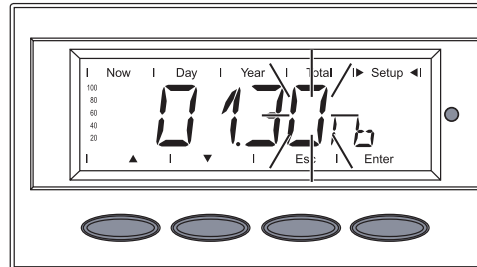

The second digit after the decimal point flashes

9. Use the 'Up' and 'Down' keys to select a value for the second digit after the decimal point
▲ ▼
10. Press the 'Enter' key

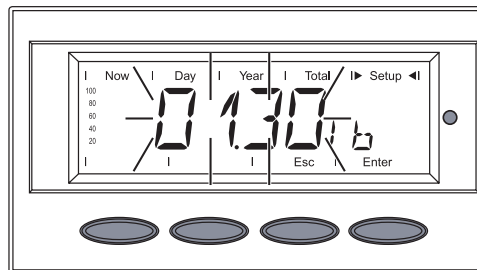

The set CO₂ reduction factor flashes

11. Press the 'Enter' key

The set CO₂ reduction factor is now accepted

12. Press the 'Esc' key to exit menu item 'CO₂' or to maintain previous setting

**Setting menu
item 'YIELD'**

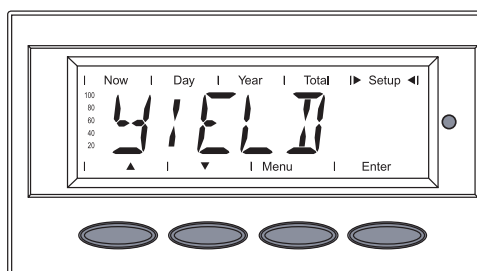

1. Select menu item 'YIELD'
2. Press the 'Enter' key

Setting menu item 'YIELD'
(continued)

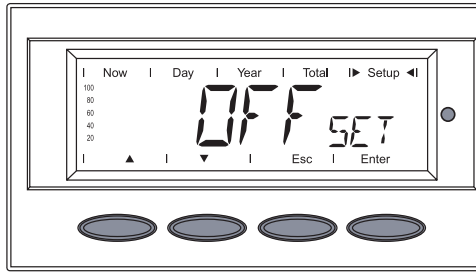

'OFFset' is shown

3. Press the 'Enter' key

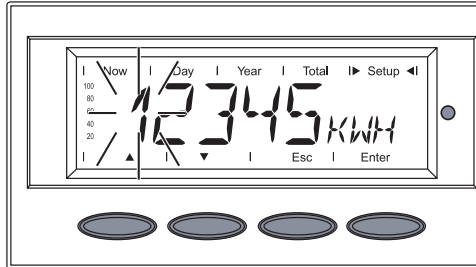

The OFFSET value is shown, the first digit flashes

3. Use the 'Up' and 'Down' keys to select a value for the first digit
▲ ▼
4. Press the 'Enter' key

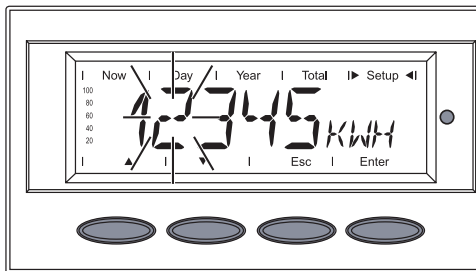

The second digit of the OFFSET value flashes

5. Use the 'Up' and 'Down' keys to select a value for the second digit
▲ ▼
6. Press the 'Enter' key

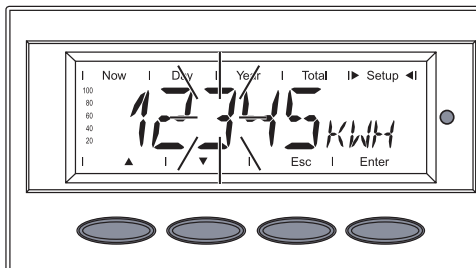

The third digit of the OFFSET value flashes

7. Use the 'Up' and 'Down' keys to select a value for the third digit
▲ ▼
8. Press the 'Enter' key

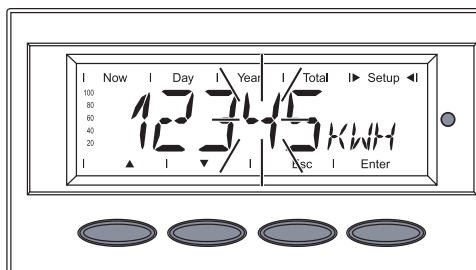

The fourth digit of the OFFSET value flashes

9. Use the 'Up' and 'Down' keys to select a value for the fourth digit
▲ ▼
10. Press the 'Enter' key

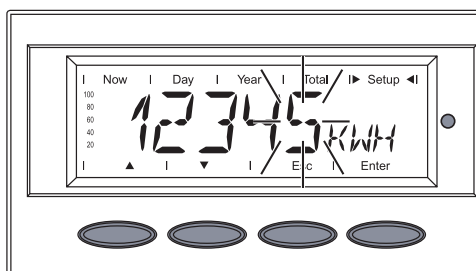

The fifth digit of the OFFSET value flashes

11. Use the 'Up' and 'Down' keys to select a value for the fifth digit
▲ ▼
12. Press the 'Enter' key

Setting menu item 'YIELD'
(continued)

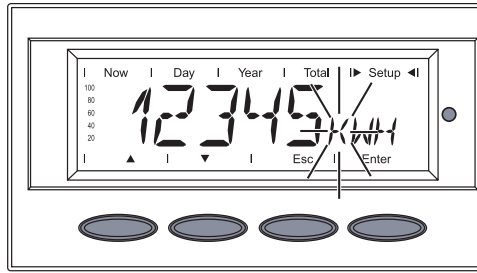

The digit for the SI prefix flashes

13. Use the 'Up' and 'Down' keys to select the SI prefix:

k = 1000
M = 1000000
▲ ▼

14. Press the 'Enter' key

The set OFF_{SET} value and the SI prefix flash

15. Press the 'Enter' key

The set OFF_{SET} value is now accepted.

'OFF_{SET}' is shown

16. Press the 'Up' or 'Down' key

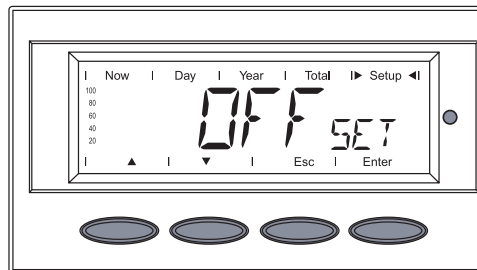
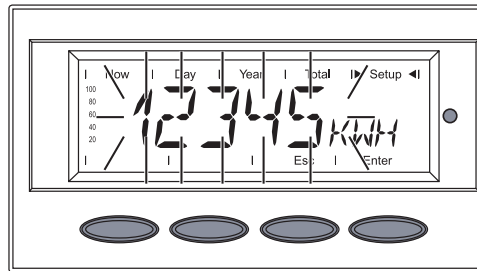

'CALI.' is shown

17. Press the 'Enter' key



The correction value in % is shown, the digit for the sign flashes

18. Use the 'Up' and 'Down' keys to select a sign for the correction value
▲ ▼

19. Press the 'Enter' key

The digit before the decimal point flashes

20. Use the 'Up' and 'Down' keys to select a value for the digit before the decimal point
▲ ▼

21. Press the 'Enter' key

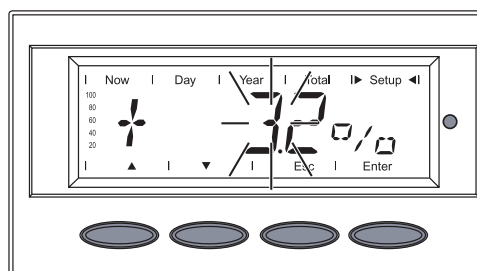
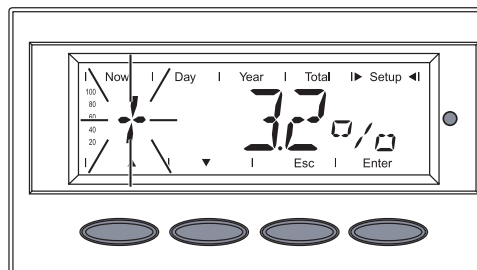

Setting menu item 'YIELD'
(continued)

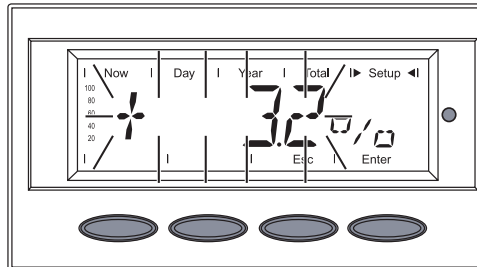
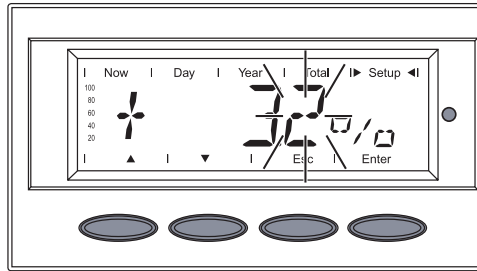

The digit after the decimal point flashes

22. Use the 'Up' and 'Down' keys to select a value for the digit after the decimal point
▲ ▼

23. Press the 'Enter' key

The set correction value flashes

24. Press the 'Enter' key

The set correction value is now accepted

'CALI.' is shown

25. Press the 'Esc' key 2 x to exit menu item 'YIELD' or to maintain previous setting

Setting menu item 'IG-NR'

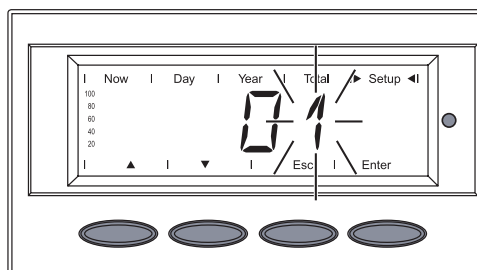
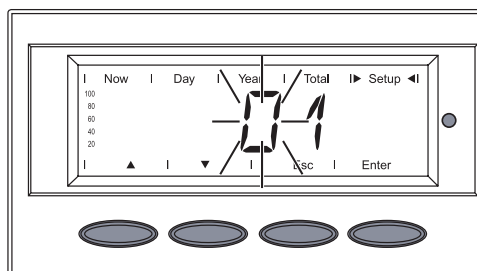
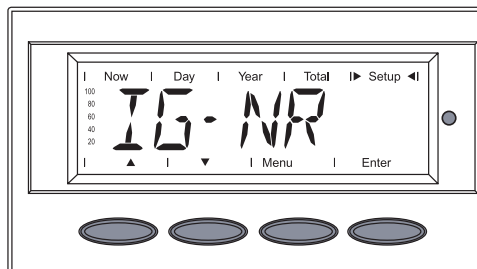

1. Select menu item 'IG-NR'
2. Press the 'Enter' key

The inverter number is shown, the first digit flashes.

3. Use the 'Up' and 'Down' keys to select a value for the first digit
▲ ▼
4. Press the 'Enter' key

The second digit flashes

5. Use the 'Up' and 'Down' keys to select a value for the second digit
▲ ▼
6. Press the 'Enter' key

Setting menu item 'IG-NR'
(continued)

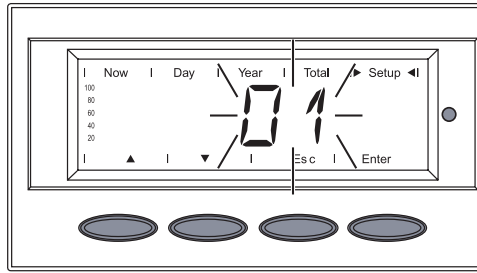

The set inverter number now flashes

7. Press the 'Enter' key

The number is accepted

8. Press the 'Esc' key to exit menu item 'IG-NR' or to maintain previous setting

Setting menu item 'DATcom'

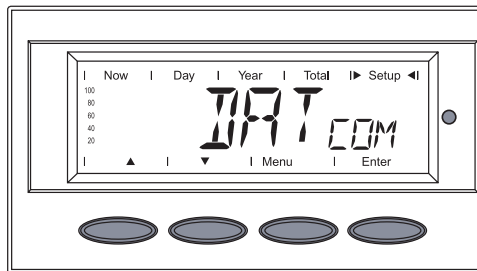

1. Select menu item 'DATcom'
2. Press the 'Enter' key

The following displays depend on whether

- a data connection is available
- a data connection is faulty or an option is not installed

Available data connection

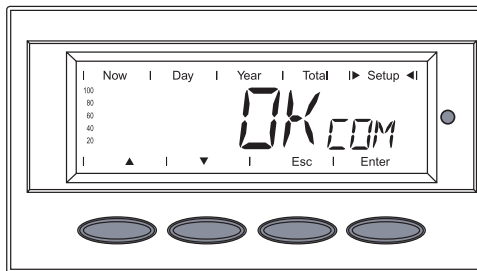

If there is a data connection available, 'OKcom' is shown.

3. Use the 'Down' key to select available data:
▼

e.g. Reset Personal Display Card ('PDCDRST') ...

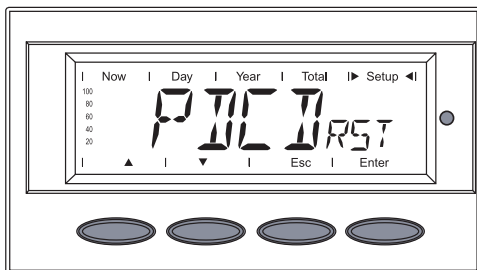

... or Reset Interface Card ('IFCDRST')

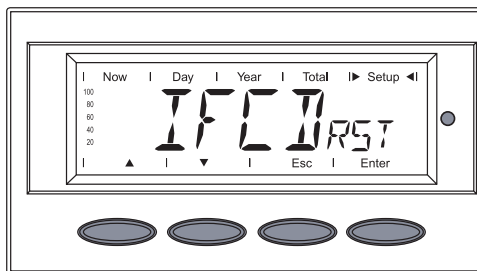

4. Press the 'Enter' key

Setting menu item 'DATcom'
(continued)

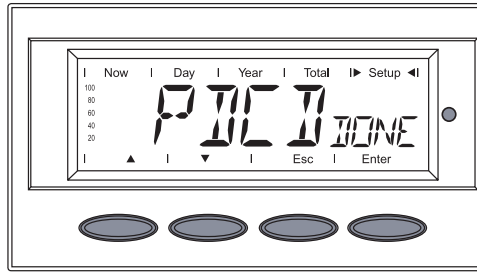

'PDCDDONE' ...

... or ...

'IFCDDONE' is shown

5. Press the 'Esc' key 2x to exit menu item 'DATcom'

Data connection faulty or an option is not installed

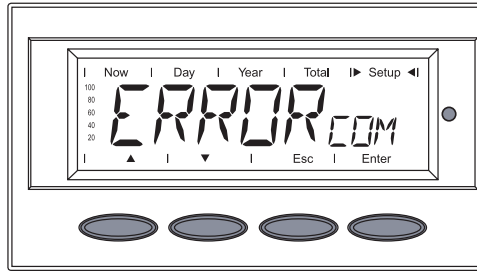

If there is a faulty data connection or options are not installed 'ERRORCOM' is shown.

3. Press the 'Esc' key to exit menu item 'DATcom'

Setting menu item 'TIME'

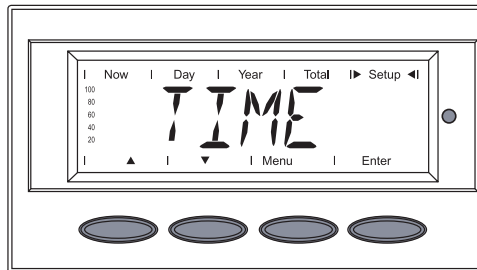

1. Select menu item 'TIME'
2. Press the 'Enter' key

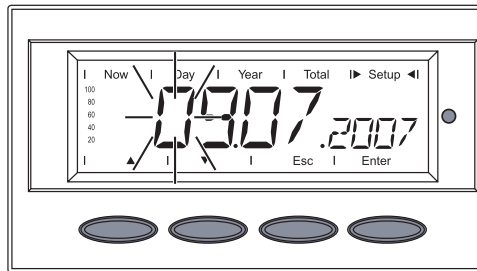

The **date** is shown (DD.MM.YYYY), the first digit for the day flashes

3. Use the 'Up' and 'Down' keys to select a value for the first day digit
▲ ▼

4. Press the 'Enter' key

The second day digit flashes

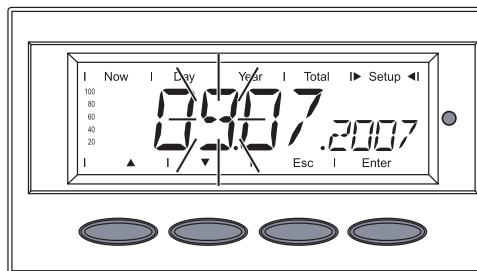

5. Use the 'Up' and 'Down' keys to select a value for the second day digit
▲ ▼

6. Press the 'Enter' key

**Setting menu
item 'TIME'**
(continued)

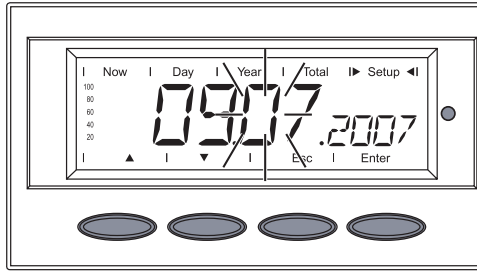

The first digit for the month
flashes

7. Use the 'Up' and 'Down' keys to
select a value for the first
month digit
▲ ▼

8. Press the 'Enter' key

The second digit for the month
flashes

9. Use the 'Up' and 'Down' keys to
select a value for the second
month digit
▲ ▼

10. Press the 'Enter' key

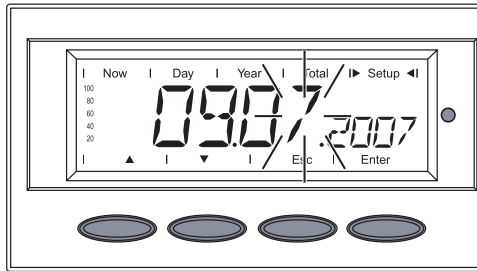

The first digit for the year flas-
hes

11. Use the 'Up' and 'Down' keys to
select a value for the first year
digit
▲ ▼

12. Press the 'Enter' key

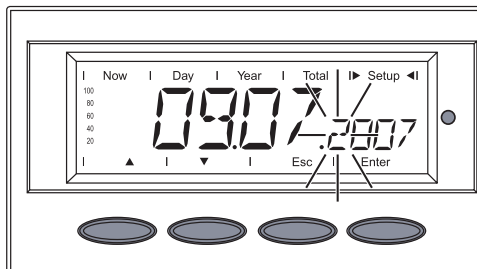

The second digit for the year
flashes

13. Use the 'Up' and 'Down' keys to
select a value for the second
year digit
▲ ▼

14. Press the 'Enter' key

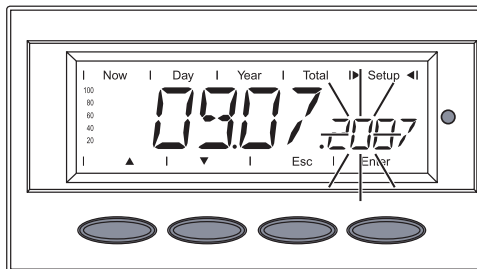

The third digit for the year
flashes

15. Use the 'Up' and 'Down' keys to
select a value for the third year
digit
▲ ▼

16. Press the 'Enter' key

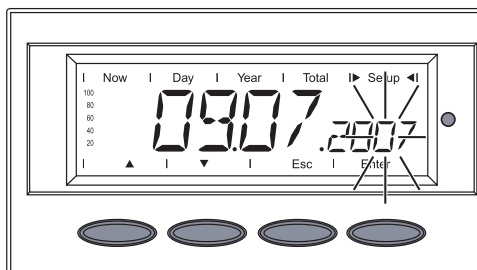

**Setting menu
item 'TIME'**
(continued)

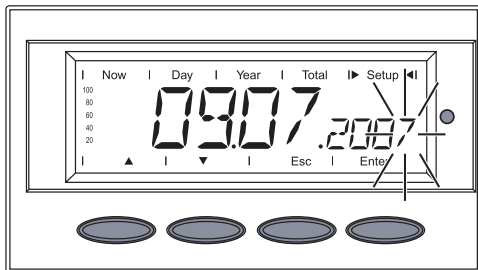

The fourth digit for the year
flashes

17. Use the 'Up' and 'Down' keys to
select a value for the fourth
year digit
▲ ▼

18. Press the 'Enter' key

The set date then flashes:

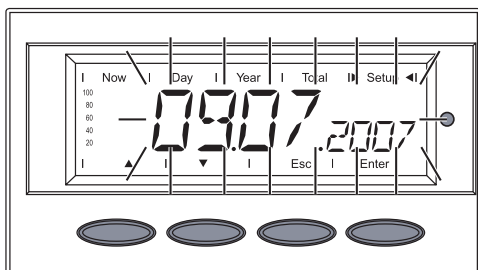

19. Press the 'Enter' key

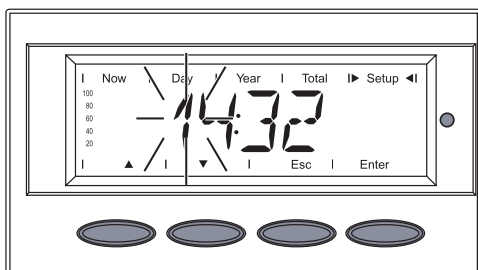

The **time** is shown (HH:MM, 0 -
24 h), the first digit for the hour
flashes

20. Use the 'Up' and 'Down' keys to
select a value for the first hour
digit
▲ ▼

21. Press the 'Enter' key

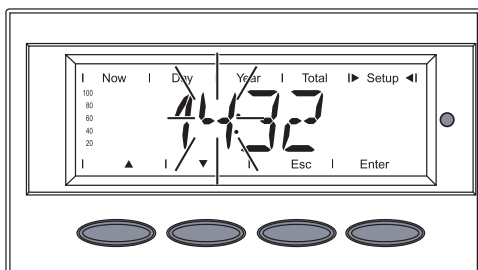

The second digit for the hour
flashes

22. Use the 'Up' and 'Down' keys to
select a value for the second
hour digit
▲ ▼

23. Press the 'Enter' key

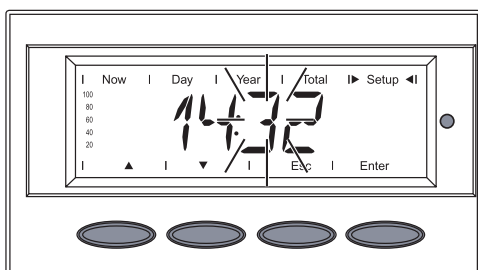

The first digit for the minutes
flashes

24. Use the 'Up' and 'Down' keys to
select a value for the first minu-
tes digit
▲ ▼

25. Press the 'Enter' key

Setting menu item 'TIME'
(continued)

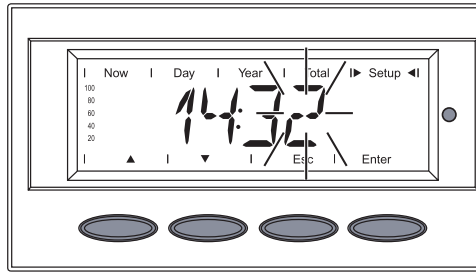

The second digit for the minutes flashes

26. Use the 'Up' and 'Down' keys to select a value for the second minutes digit

▲ ▼

27. Press the 'Enter' key

The set time flashes

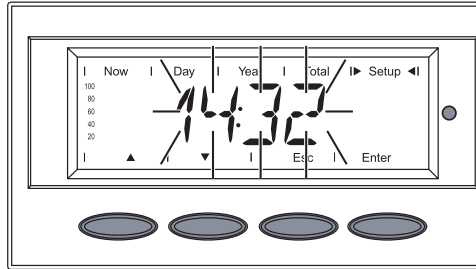

28. Press the 'Enter' key to apply the time

29. Press the 'Esc' key to exit menu item 'TIME' or to maintain previous setting

Displaying menu item 'STATEPS'

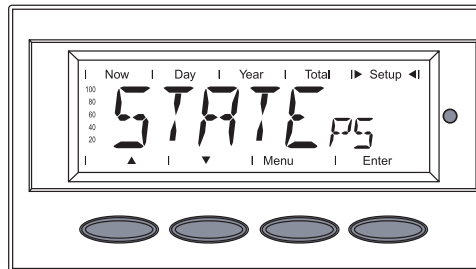

1. Select menu item 'STATEPS'
2. Press the 'Enter' key

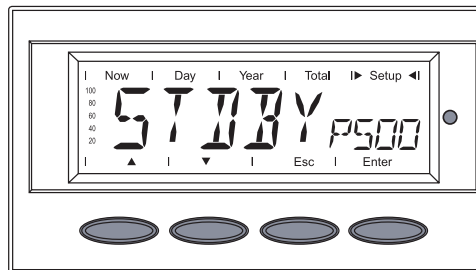

The status of the first power stage set PS00 is shown, e.g.: STDBY_{PS00}

STDBY = standby (no grid feed)

3. Press the 'Enter' key to display the last status message saved

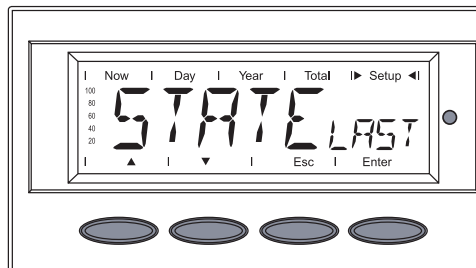

The display switches between

...

'STATELAST'

and

Displaying menu item 'STATEPs' (continued)

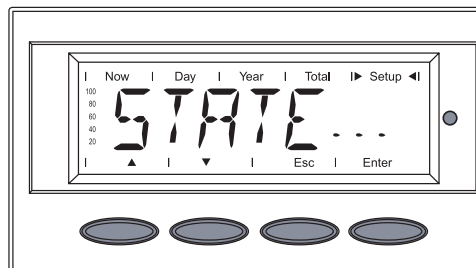
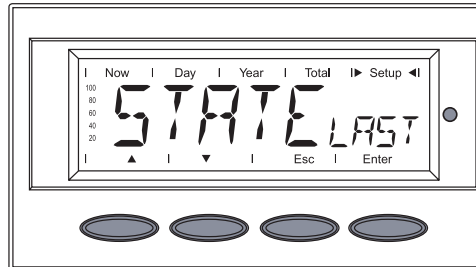
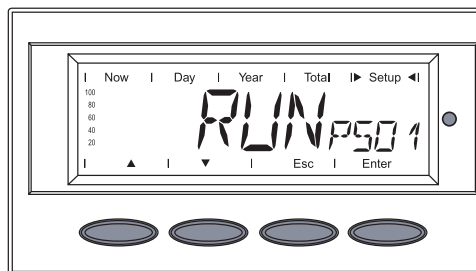
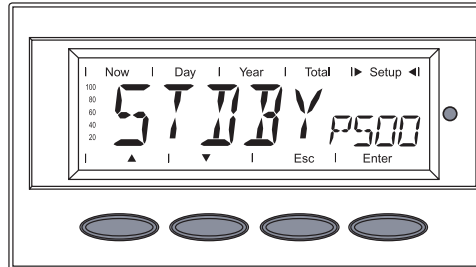
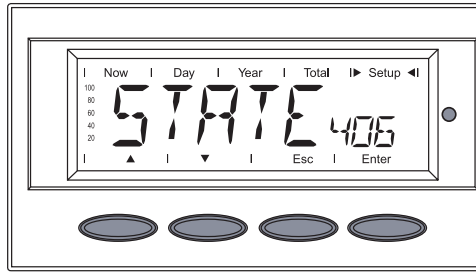

Displaying menu item 'VERSION'

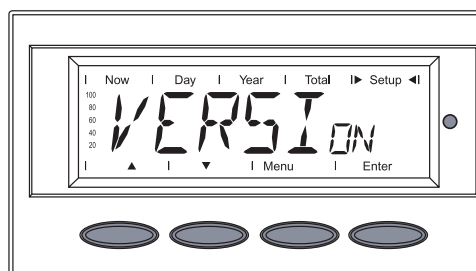

the last saved status message.

4. Press the 'Esc' key

The status of the first power stage set PS00 is shown again

5. Use the 'Down' key to select the second or third power stage set PS01 or PS02, if available.
 - ▼

The status of the selected power stage set is shown, e.g.: RUN_{PS01}

RUN = active grid feed

6. Press the 'Enter' key to display the last status message saved

The display switches between ...

'STATE_{LAST}'

and

the last saved status message.

7. Press the 'Esc' key 2x to exit menu item 'STATE_{Ps}'

1. Select menu item 'VERSION'
2. Press the 'Enter' key

**Displaying
menu item
'VERSION'
(continued)**

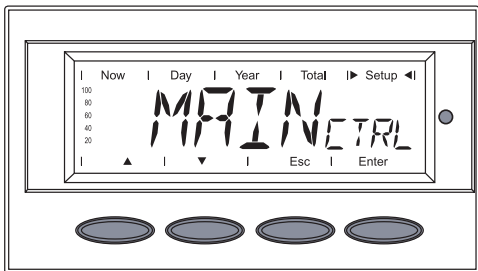
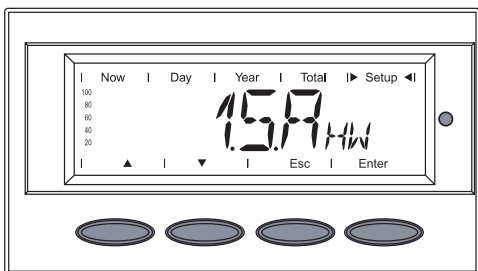
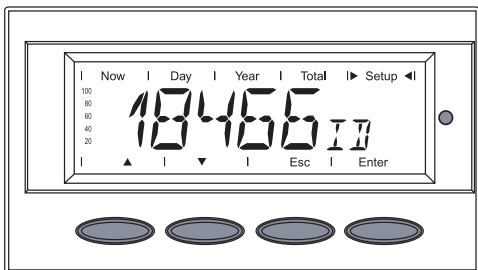
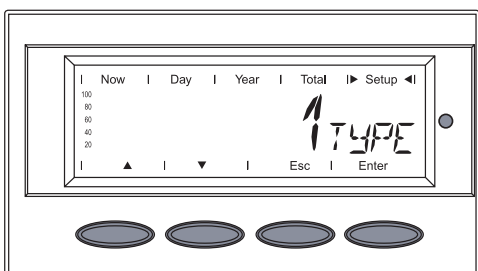
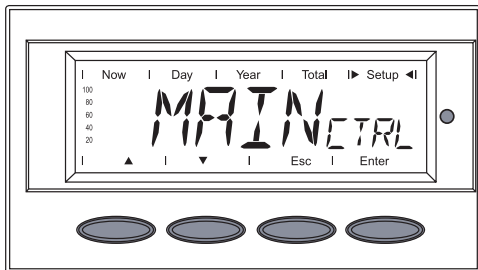

'MAINCTRL' is shown

3. Press 'Enter' to display the version number of the IG Brain unit

The version number of the IG Brain unit is shown

4. Press the 'Down' key to display the component ID.
▼

The component ID of the IG Brain unit is shown

5. Press the 'Down' key to display the identification number of the IG Brain unit
▼

The identification number of the IG Brain unit is shown

6. Press the 'Down' key to display the hardware version of the IG Brain unit
▼

The hardware version of the IG Brain unit is shown

7. Press the 'Esc' key

'MAINCTRL' is shown

8. Press the 'Down' key to display the power stage sets
▼

**Displaying
menu item
'VERSION'
(continued)**

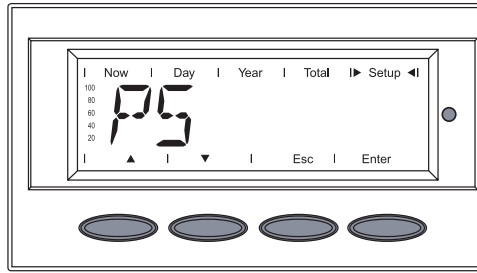

'PS' is shown

9. Press the 'Enter' key

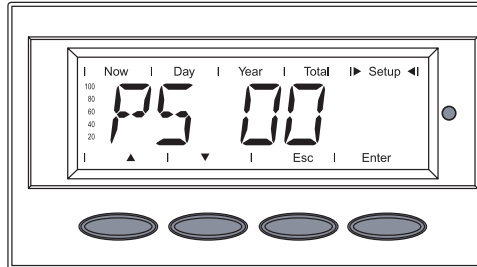

The first power stage set 'PS 00' is shown

10. Select the desired power stage set using the 'Down' key



11. Press the 'Enter' key

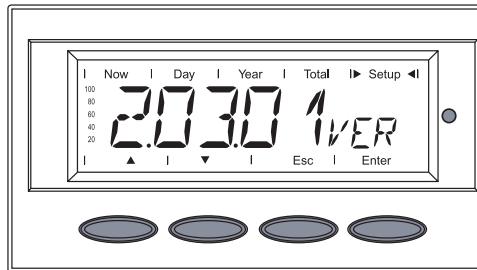

The version number of the selected power stage set is shown

12. Press the 'Down' key to display the component ID

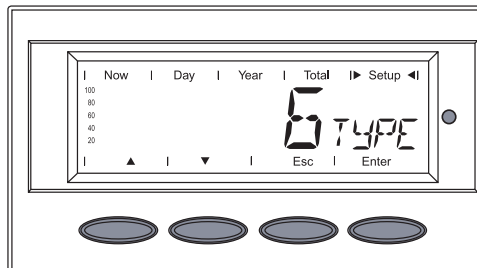

The component ID of the selected power stage set is shown

13. Press the 'Down' key to display the power stage set identification number

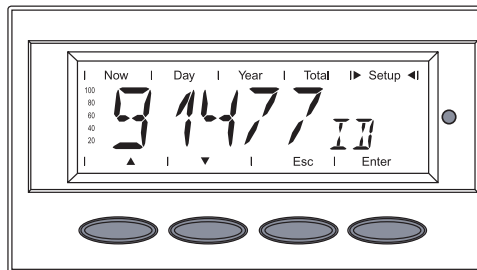

The identification number of the selected power stage set is shown

14. Press the 'Down' key to display the hardware version of the power stage set

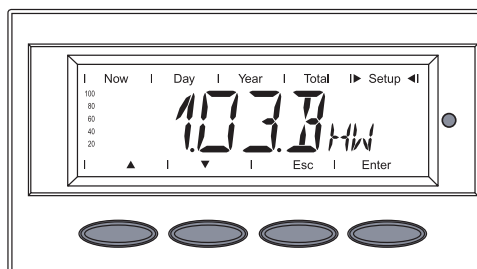

The hardware version of the selected power stage set is shown

15. Press the 'Esc' key

**Displaying
menu item
'VERSlon'**
(continued)

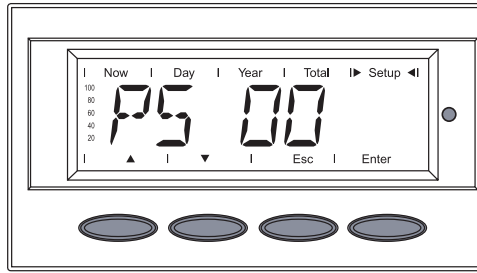

The selected power stage set is shown

16. Press the 'Esc' key

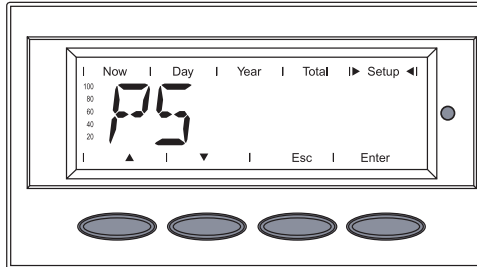

'PS' is shown

17. Press the 'Esc' key to exit menu item 'VERSlon'

Troubleshooting and Maintenance

Status Diagnosis and Troubleshooting

Displaying Status Codes

Your Fronius IG Plus unit is equipped with a self diagnostic system that automatically identifies a large number of possible operation issues by itself and displays them on the screen. This enables you to know immediately if there are any malfunctions in the Fronius IG Plus, the photovoltaic system or any installation or operating errors.

Whenever the self diagnostic system has identified a particular issue, the respective status code is shown on the screen.

Important Display of a status code for a short time may be the result of the control procedures of your Fronius IG Plus unit. If it subsequently continues to operate normally, there has not been a system error.

Normal operation status codes

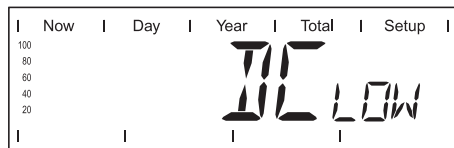

The open-circuit voltage of the solar modules is too low.

As soon as the open-circuit voltage exceeds 290 V, the Fronius IG Plus unit starts synchronizing with the grid (display shows 'SYNCAc').

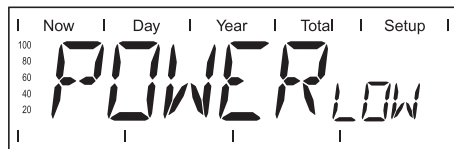

The total power output of the solar modules is insufficient.

After a short time the Fronius IG Plus resumes grid synchronization (display shows 'SYNCAc').

Total failure

If the display remains dark after sunrise:

- Check the open-circuit voltage of the solar modules at the connections of the Fronius IG Plus:

Open-circuit voltage < 290 V ... error in the photovoltaic system

Open-circuit voltage > 290 V ... may indicate a basic fault in the Fronius IG Plus. In this case, notify a Fronius-trained service technician.

Status Codes on Fronius IG Plus with several power stage sets

A special status diagnostic is run if an error occurs in a Fronius IG Plus with several power stage sets.

It is also possible to call up state messages even if there is no actual error in existence. This form of status polling may be found in the section 'The Setup Menu'.

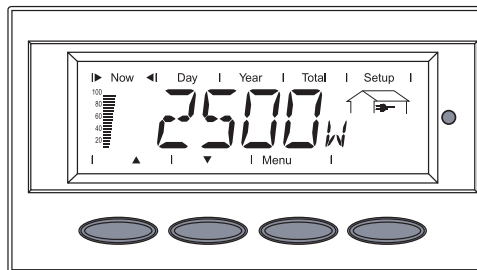

Display in normal operation

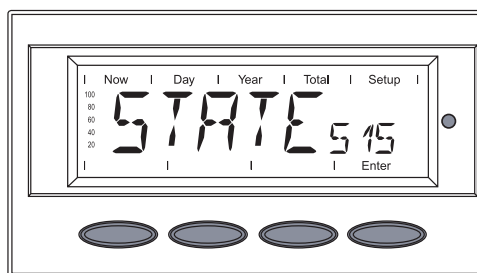

When there is an error in one of the two power stage sets, the display flashes between 'STATE' and the corresponding status message (e.g. 'STATE 515')

and

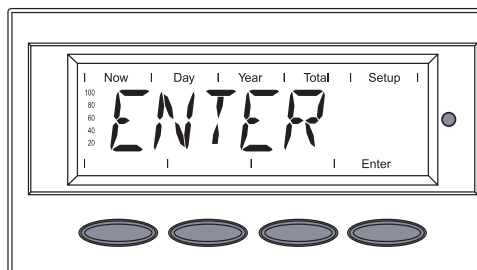

'ENTER'

- Press the 'Enter' key twice

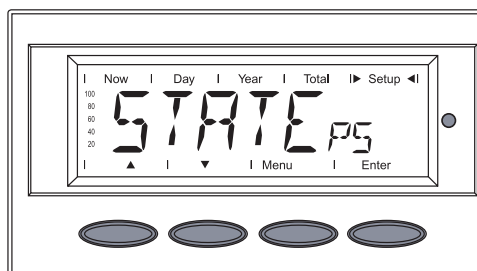

- The status display of the power stage sets 'STATEPS' appears
- Press the 'Enter' key

Additional information can be found in 'The Setup Menu' section, STATEPS' Menu item

Class 1 Status Codes

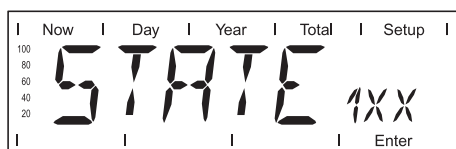

Status codes of class 1 are typically temporary. Their cause lies in the grid.

The first reaction of your Fronius IG Plus unit is to disconnect from the grid. Subsequently, the grid will be checked for the duration of the observation period stipulated. If after the end of this period no further defect is identified, your Fronius IG Plus unit resumes operating and feeding power into the grid.

Class 1 Status Codes

(continued)

Important The 2nd position x defines the exact network point for the following status messages:

- 0 = several / all 3 phases
- 1 = L1
- 2 = L2
- 3 = L3

1x2

AC voltage too high

Behavior Grid conditions are thoroughly tested and as soon as they are again within the permissible range, the Fronius IG Plus will resume feeding power into the grid.

Remedy Check grid connections and fuses
If this status message keeps recurring, contact your system installer

1x3

AC voltage too low

Behavior Grid conditions are thoroughly tested and as soon as they are again within the permissible range, the Fronius IG Plus will resume feeding power into the grid.

Remedy Check grid connections and fuses
If this status message keeps recurring, contact your system installer

1x5

AC frequency too high

Behavior Grid conditions are thoroughly tested and as soon as they are again within the permissible range, the Fronius IG Plus will resume feeding power into the grid.

Remedy Check grid connections and fuses
If this status message keeps recurring, contact your system installer

1x6

AC frequency too low

Behavior Grid conditions are thoroughly tested and as soon as they are again within the permissible range, the Fronius IG Plus will resume feeding power into the grid.

Remedy Check grid connections and fuses
If this status message keeps recurring, contact your system installer

Class 1 Status Codes
(continued)

1x7	
No grid voltage detected	
Behavior	As soon as the grid conditions have returned to admissible range, Fronius IG Plus resumes feeding power into the grid
Remedy	Check grid connections and fuses; If the status code does not disappear you should contact your electrical contractor

108	
Islanding detected	
Behavior	As soon as grid frequency has returned to admissible range, Fronius IG Plus resumes feeding power into the grid
Remedy	Check grid voltage; If the status code does not disappear you should contact your electrical contractor

109	
General grid error	
This error is always displayed first for grid errors. After reviewing all power stage sets, the grid error is specified with more detail: 1x1 / 1x4 or the display remains at '109' (e.g. when 2 phases report '104' and one phase '101')	
Behavior	Grid conditions are thoroughly tested and as soon as they are again within the permissible range, the Fronius IG Plus will resume feeding power into the grid.
Remedy	Check grid connections and fuses If this status message keeps recurring, contact your system installer

Class 2 Status Codes

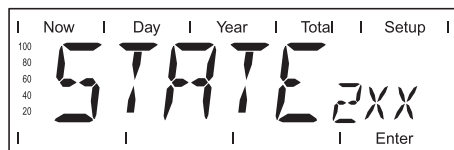

Status codes of class 2 are typically temporary. Their cause lies in the grid.

The first reaction of your Fronius IG Plus unit is to disconnect from the grid. Subsequently, the grid will be checked for the duration of the observation period stipulated. If after the end of this period no further defect is identified, your Fronius IG Plus unit resumes operating and feeding power into the grid.

Important The 2nd position x defines the exact network point for the following status messages:

- 0 = several / all 3 phases
- 1 = L1
- 2 = L2
- 3 = L3

Class 2 Status Codes
(continued)

2x2

Grid voltage exceeds admissible limits

Behavior As soon as the grid voltage has returned to admissible range, Fronius IG Plus resumes feeding power into the grid

Remedy Check grid voltage; if the status code persists you should contact your electrical contractor

2x3

Grid voltage below admissible limits

Behavior As soon as the grid voltage has returned to admissible range, Fronius IG Plus resumes feeding power into the grid

Remedy Check grid voltage, if the status code persists you should contact your electrical contractor

207

No grid voltage detected

Behavior As soon as the grid conditions have returned to admissible range, Fronius IG Plus resumes feeding power into the grid

Remedy Check grid connections and fuses; if the status code does not disappear you should contact your electrical contractor

Class 3 Status Codes

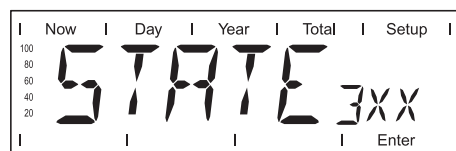

Class 3 comprises status codes that may appear during operation of feeding power supply, that do not cause a permanent interruption of the operation of feeding power into the grid.

After automatic disconnection from the grid and waiting for its conditions to return to those stipulated, your Fronius IG Plus unit will try to resume feed-in operation.

301

Over-current (AC)

Behavior Short interruption of power feeding into the grid, caused by overcurrent

Remedy Fronius IG Plus returns to startup phase automatically

Should the status code persist, you should contact your electrical contractor

Class 3 Status Codes
(continued)

302

Over-current (DC)

Behavior	Short interruption of power feeding into the grid, caused by overcurrent Fronius IG Plus returns to startup phase
Remedy	automatically Should the status code persist, you should contact your electrical contractor

303

Over-temperature AC side

Behavior	Short interruption of power feeding into the grid caused by overtemperature
Remedy	after a two minutes cooling phase your Fronius IG Plus unit restarts Should the status code persist, you should contact your electrical contractor

304

Over-temperature DC-side

Behavior	Short interruption of power feeding into the grid caused by overtemperature
Remedy	after a two minutes cooling phase your Fronius IG Plus unit restarts Should the status code persist, you should contact your electrical contractor

305

No power transfer to grid possible

Behavior	Continual interruption of grid feed operation
Remedy	Should the status code persist, you should contact your electrical contractor

'POWER_{Low}' (306)

Intermediate circuit voltage has dropped below permissible threshold value for feed in.

this error is shown on the Fronius IG Plus in plain text

Behavior	Short interruption of power feeding into the grid Fronius IG Plus resumes starting up phase
Remedy	automatically Should the status code persist, you should contact your electrical contractor

Class 3 Status Codes
(continued)

'DCLow' (307)

DC-input voltage is too low for feed in
this error is shown on the Fronius IG Plus in plain text

Behavior	Short interruption of power feeding into the grid Fronius IG Plus resumes starting up phase
Remedy	automatically Should the status code persist, you should contact your electrical contractor

Important The status messages 'POWERlow' (306) and 'DClow' (307) occur every morning and evening. No corrective measures are required for these status messages.

308

Intermediate circuit voltage too high

Behavior	Short interruption of power feeding into the grid Fronius IG Plus resumes starting up phase
Remedy	automatically Should the status code persist, you should contact your electrical contractor

Class 4 Status Codes

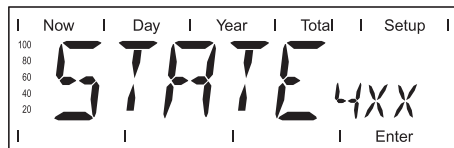

Class 4 status codes may require the intervention of a trained Fronius service technician.

401

No internal communication with power stage

Behavior	If it is possible, your Fronius IG Plus unit will resume the power feeding operation after successfully completing another attempt to connect
Remedy	If status code persists, you should contact a Fronius-trained service technician

402

Faulty EEPROM access

Behavior	If it is possible, your Fronius IG Plus unit will resume the power feeding operation after successfully completing another attempt to connect
Remedy	If status code persists, you should contact a Fronius-trained service technician

Class 4 Status Codes
(continued)

403 EEPROM faulty	
Behavior	If it is possible, your Fronius IG Plus unit will resume the power feeding operation after successfully completing another attempt to connect
Remedy	If status code persists, you should contact a Fronius-trained service technician

406 AC temperature sensor faulty	
Behavior	Fronius IG Plus disconnects from the grid for safety reasons
Remedy	If status code persists, you should contact a Fronius-trained service technician

407 DC temperature sensor faulty	
Behavior	Fronius IG Plus disconnects from the grid for safety reasons
Remedy	If status code persists, you should contact a Fronius-trained service technician

408 Direct current feed in	
Behavior	Fronius IG Plus disconnects from the grid for safety reasons
Remedy	If status code persists, you should contact a Fronius-trained service technician

412 The setting “fixed voltage“ has been selected instead of the MPP-voltage operation and the voltage is set to too low a value, or DC voltage exceeds allowable limits.	
Behavior	Fixed voltage lower than the current MPP-voltage
Remedy	If status code persists, you should contact a Fronius-trained service technician, or remove excess modules so DC voltage fits within inverter limits.

413 Control problems	
Behavior	The Fronius IG Plus briefly disconnects from the grid, if AC voltage or frequency are out of range
Remedy	If status code persists, you should contact a Fronius-trained service technician

414 EEPROM faulty	
Behavior	Memory deleted
Remedy	If status code persists, you should contact a Fronius-trained service technician

Class 4 Status Codes
(continued)

416 Communication with IG-Brain not possible	
Behavior	The Operating Status LED lights up orange, then the Fronius IG Plus attempts a restart
Remedy	If status code persists, contact a Fronius-trained service technician

417 Two power stage sets have the same PCB number	
Behavior	The Fronius IG Plus stops feeding power into the grid, the display shows a critical error via a red Operating Status LED
Remedy	If status code persists, contact a Fronius-trained service technician

419 Two or more power stage sets with an identical software serial number detected	
Behavior	The Fronius IG Plus stops feeding power into the grid, the display shows a critical error via a red Operating Status LED
Remedy	If status code persists, contact a Fronius-trained service technician

421 PCB number has been set incorrectly	
Behavior	The Fronius IG Plus stops feeding power into the grid, the display shows a critical error via a red Operating Status LED
Remedy	If status code persists, contact a Fronius-trained service technician

425 Communication with the power stage set is not possible	
Behavior	The Operating Status LED lights up orange, then the Fronius IG Plus attempts a restart
Remedy	If status code persists, contact a Fronius-trained service technician

431 All power stage sets are in boot mode	
Behavior	The Fronius IG Plus stops feeding power into the grid, the display shows a critical error via a red Operating Status LED
Remedy	Update firmware using Bootloader or 'Fronius Solar.update/IG Plus'

Class 4 Status Codes
(continued)

439	The MPP master power stage set is switched off because of an error in a slave power stage set (in the balance mode)
Behavior	The Fronius IG Plus stops feeding power into the grid, the display shows a critical error via a red Operating Status LED
Remedy	If status code persists, contact a Fronius-trained service technician

442	No phase master for a phase
Behavior	The Fronius IG Plus stops feeding power into the grid, the display shows a critical error via a red Operating Status LED
Remedy	If status code persists, contact a Fronius-trained service technician

443	Energy transfer not possible
Behavior	The Fronius IG Plus stops feeding power into the grid, the display shows a critical error via a red Operating Status LED
Remedy	If status code persists, contact a Fronius-trained service technician

445	Invalid power stage set configuration
Behavior	The Fronius IG Plus stops feeding power into the grid, the display shows a critical error via a red Operating Status LED
Remedy	If status code persists, contact a Fronius-trained service technician

446	Internal communication error with NL-MON PC board
Behavior	If it is possible, your Fronius IG Plus unit will resume the power feeding operation after successfully completing another attempt to connect
Remedy	If status code persists, contact a Fronius-trained service technician

447	NL-MON PC board stopped grid monitoring
Behavior	If it is possible, your Fronius IG Plus unit will resume the power feeding operation after successfully completing another attempt to connect
Remedy	If status code persists, contact a Fronius-trained service technician

Class 4 Status Codes
(continued)

448	
N (neutral) conductor not connected	
Behavior	Fronius IG Plus disconnects from grid for safety reasons
Remedy	Check grid setup, grid connections and fuses If status code persists, contact your electrical contractor or a Fronius-trained service technician

450	
The monitoring of the power stage set main processor 'Guard' is active	
Behavior	The Fronius IG Plus stops feeding power into the grid, the display shows a critical error via a red Operating Status LED
Remedy	If status code persists, contact a Fronius-trained service technician

451	
The EEPROM Guard Control is defective	
Behavior	The Fronius IG Plus stops feeding power into the grid, the display shows a critical error via a red Operating Status LED
Remedy	If status code persists, contact a Fronius-trained service technician

452	
Communication between 'Guard' and the digital signal processor (DSP) has been interrupted	
Behavior	The Fronius IG Plus stops feeding power into the grid, the display shows a critical error via a red Operating Status LED
Remedy	If status code persists, contact a Fronius-trained service technician

453	
Error in grid voltage recording	
Behavior	The Fronius IG Plus stops feeding power into the grid, the display shows a critical error via a red Operating Status LED
Remedy	If status code persists, contact a Fronius-trained service technician

454	
Error in grid frequency recording	
Behavior	The Fronius IG Plus stops feeding power into the grid, the display shows a critical error via a red Operating Status LED
Remedy	If status code persists, contact a Fronius-trained service technician

Class 4 Status Codes
(continued)

455

Reference power source for AC measurement is operating outside of tolerances

Behavior The Fronius IG Plus stops feeding power into the grid, the display shows a critical error via a red Operating Status LED

Remedy If status code persists, contact a Fronius-trained service technician

456

Error during anti-islanding test

Behavior The Fronius IG Plus stops feeding power into the grid, the display shows a critical error via a red Operating Status LED

Remedy If status code persists, contact a Fronius-trained service technician

457

Grid relay stuck

Behavior The Fronius IG Plus stops feeding power into the grid, the display shows a critical error via a red Operating Status LED

Remedy If status code persists, contact a Fronius-trained service technician

460

Reference power source for the digital signal processor (DSP) is operating outside of tolerances

Behavior The Fronius IG Plus stops feeding power into the grid, the display shows a critical error via a red Operating Status LED

Remedy If status code persists, contact a Fronius-trained service technician

461

Error in DSP data memory

Behavior The Fronius IG Plus stops feeding power into the grid, the display shows a critical error via a red Operating Status LED

Remedy If status code persists, contact a Fronius-trained service technician

464

Display error

The software and/or hardware versions of the display and IG Brain are not compatible.

Behavior The Fronius IG Plus stops feeding power into the grid, the display shows a critical error via a red Operating Status LED

Remedy Update firmware using Bootloader or 'Fronius Solar.update/IG Plus'

Class 4 Status Codes
(continued)

465	
Display error	
The UI command sent from the IG Brain is not recognized by the present display version.	
Behavior	The Fronius IG Plus stops feeding power into the grid, the display shows a critical error via a red Operating Status LED
Remedy	If status code persists, contact a Fronius-trained service technician

466	
Display error	
The display was not detected.	
Behavior	The Fronius IG Plus stops feeding power into the grid, the display shows a critical error via a red Operating Status LED
Remedy	Check the display for damage, connect display, check ribbon wire for damage, check IG Brain for damage If status code persists, contact a Fronius-trained service technician

467	
The display has not received a start command from the IG Brain for longer than 6 s	
Behavior	The Fronius IG Plus will automatically attempt to connect again and, if possible, resume feeding power into the grid
Remedy	If status code persists, contact a Fronius-trained service technician

469	
Throttle connected to wrong poles	
Behavior	The Fronius IG Plus stops feeding power into the grid, the display shows a critical error via a red Operating Status LED
Remedy	Properly connect throttle If status code persists, contact a Fronius-trained service technician

470	
The buck converter relay does not open at high DC voltage	
Behavior	The Fronius IG Plus stops feeding power into the grid, the display shows a critical error via a red Operating Status LED
Remedy	Check system configuration If status code persists, contact a Fronius-trained service technician

472	
Ground fault detected	
Behavior	Inverter is blocked from feeding energy into the grid
Remedy	Change GFDI fuse

Class 5 Status Codes

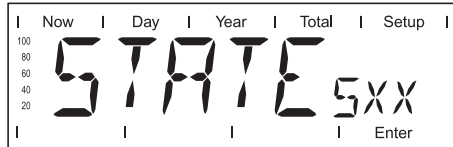

Class 5 status codes generally do not impair the operation of feeding power into the grid. They will be displayed until the service code is acknowledged by pressing a key (the Fronius IG Plus unit, however, continues working normally in the background)

- press any key
- error message disappears

501

defective fan

Description Low power generation because the temperature in the unit is too high

Remedy If status code persists, contact a Fronius-trained service technician

504

No Solar Net communication possible

Description Fronius IG Plus address issued twice
Remedy change Fronius IG Plus address (section: 'The Setup Menu')

Description The LocalNet components required are in the Fronius IG Plus unit: still, communication is not presently possible

Remedy Status code will disappear after changing the Fronius IG Plus address

505

EEPROM faulty

Description Data from the Setup menu are lost

Remedy Automatic rectification

506

EEPROM faulty

Description Data from the "Total" menu is lost

Remedy Automatic rectification

507

EEPROM faulty

Description Data from the menu 'Day' / 'Year' is lost

Remedy Automatic rectification

508

Fronius IG Plus address is faulty

Description Address for data communication is no longer saved

Remedy Set address again

Class 5 Status Codes
(continued)

509	24h no feed in
Description	e.g. solar modules covered in snow
Remedy	e.g. remove snow from solar modules check wiring, DC disconnect, fuses, etc.

510	EEPROM faulty
Description	SMS settings were restored to standard
Remedy	If necessary, reconfigure SMS

511	EEPROM faulty
Description	Sensor card settings were restored to standard
Remedy	If necessary, reconfigure metering channels

512	Too many power stage sets in the system
Description	Too many power stage sets have been detected in the system
Remedy	If Service-Code persists, contact a Fronius-trained service technician

513	Power stage set in boot mode
Description	One or more power stage sets cannot be activated because they are in boot mode.
Remedy	Update power stage set firmware

514	No communication with one of the power stage sets
Description	Warning message from one of the power stage sets, second power stage set working normally
Remedy	If Service-Code persists, contact a Fronius-trained service technician

515	One or more power stage sets notified a STATE 406 / 407 / 409 / 410
Description	Temperature sensor on PINCI PC board faulty or not connected properly
Remedy	Check temperature sensor on PINCI PC board If Service-Code persists, contact a Fronius-trained service technician

516	Status codes present for one of the power stage sets
Description	It is not possible to activate all power stage sets
Remedy	Carry out analysis. Please see section entitled „The Setup Menu“ and „State_PS“ for further details. If Service-Code persists, contact a Fronius-trained service technician

Class 5 Status Codes
(continued)

517	
Change of master has taken place	
Description	Transformer not connected / not plugged in Bridge short-circuit
Remedy	Detection of intermediate circuit voltage damaged Check possible errors referred to in 'Description'. If Service-Code persists, contact a Fronius-trained service technician

550	
String fuse defective	
Description	One or more string fuses are defective
Remedy	Measure string fuses and replace any that are defective

550	
Jumper set incorrectly	
Description	The jumper on the Print C-Box was not reset to the 'SMON' position after the solar module strings were checked
Remedy	Set the jumper on the Print C-Box to the 'SMON' position

553	
Phase master deactivated due to frequently occurring errors	
Description	A reintegration of the power stage set into the Mix network is being attempted at a later time
Remedy	automatically by itself; If Service-Code persists, contact a Fronius-trained service technician

554	
NL-Mon EEPROM error	
Description	Default set switch off limits were restored automatically
Remedy	System depending changes in the service menu 'Advanced' have to be done again; If Service-Code persists, contact a Fronius-trained service technician

Customer Service

Important Please contact your Fronius dealer or a Fronius-trained service partner if

- an error appears frequently or for a long period of time
- an error appears that is not listed in the tables

Maintenance

Safety



WARNING! An electrical shock can be fatal. Danger from grid voltage and DC voltage from solar modules.

- The connection area should only be opened by a licensed electrician.
- The separate power stage set area should only be disconnected from the connection area after first being disconnected from the grid power.
- The separate power stage set area should only be opened by Fronius-trained service personnel.

Never work with live wires! Prior to all connection work, make sure that the AC and DC wires are not charged.

The DC main switch is only used to switch off power to the power stage set. When the DC main switch is turned off, the connection area is still energized.

These servicing instructions are for use by qualified personnel only. To reduce the risk of electric shock, do not perform any servicing other than that specified in the operating instructions.



WARNING! An electrical shock can be fatal. Danger from residual voltage from capacitors.

You must wait until the capacitors have discharged. Discharge takes 5 minutes.

General

The Fronius IG Plus is designed so that it does not require additional maintenance.

However, there are a few points to keep in mind during operation to ensure that the inverter functions optimally.

Operation in Dusty Envi- ronments

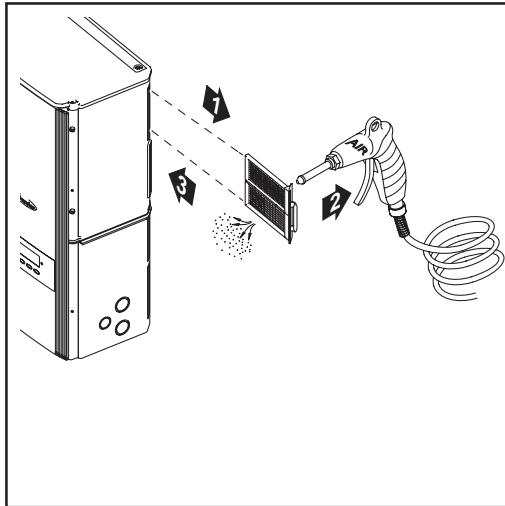

When operating the inverter in extremely dusty environments: Remove the fan cover and clean the integrated fly screen as required

Opening Fronius IG Plus for Service/ Maintenance

Procedure for opening the Fronius IG Plus for service or maintenance:

1. Disconnect the AC and DC supply from the inverter
2. Open the connection area
3. Turn off DC main switch
4. Allow the capacitors to discharge (5 minutes)
5. Remove metal covers
6. Remove the plastic dividers
7. Remove string fuses
8. Disconnect DC wire
9. Disconnect AC wire

Replacing String Fuses

Safety



WARNING! An electrical shock can be fatal. Danger from grid voltage and DC voltage from solar modules.

- The connection area should only be opened by a licensed electrician.
- Never work with live wires! Prior to all connection work, make sure that the AC and DC wires are not charged.
- The DC main switch is only used to switch off power to the power stage set. When the DC main switch is turned off, the connection area is still energized.

These servicing instructions are for use by qualified personnel only. To reduce the risk of electric shock, do not perform any servicing other than that specified in the operating instructions.



WARNING! An electrical shock can be fatal. Danger from residual voltage from capacitors.

You must wait until the capacitors have discharged. Discharge takes 5 minutes.

Preparation



NOTE

Disconnected AC and DC supply from the inverter.

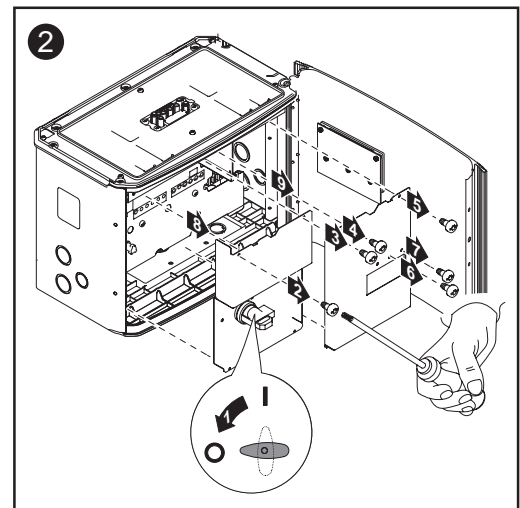
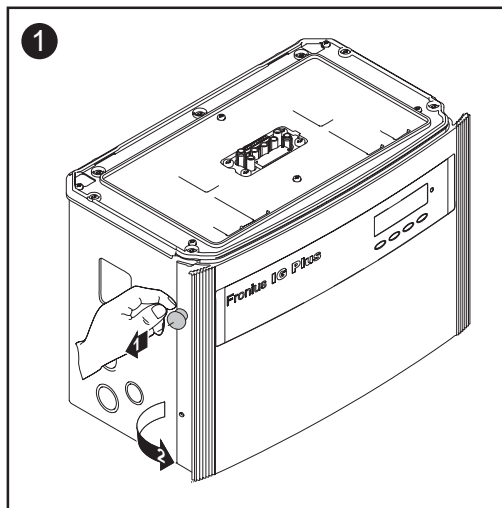

Preparation (continued)

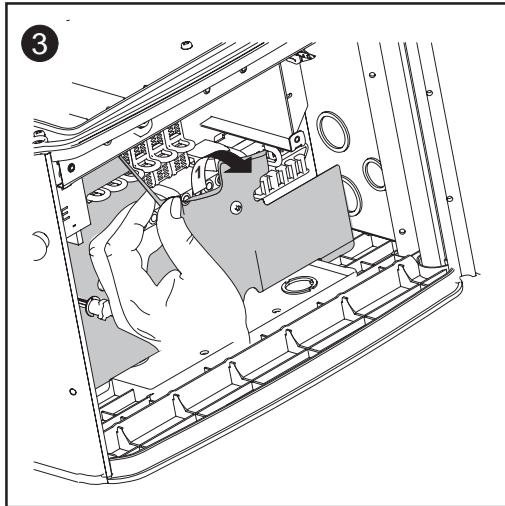

Lift up plastic dividers in the area of the string fuses

Replacing String Fuses



WARNING! An electrical shock can be fatal. Danger from DC voltage from solar modules.

- Never remove a fuse, while it is under load.
- Fuse covers are for installation purposes only. They offer no protection against contact.

1 Test the fuse holder at the terminal for continuity



NOTE Only use fuses for solar modules that meet the Criteria for the Proper Selection of String Fuses

Fuse data: Diameter 0.406 x 1.378 - 1.496 in.
(10.3 x 35 - 38 mm), 600 V DC

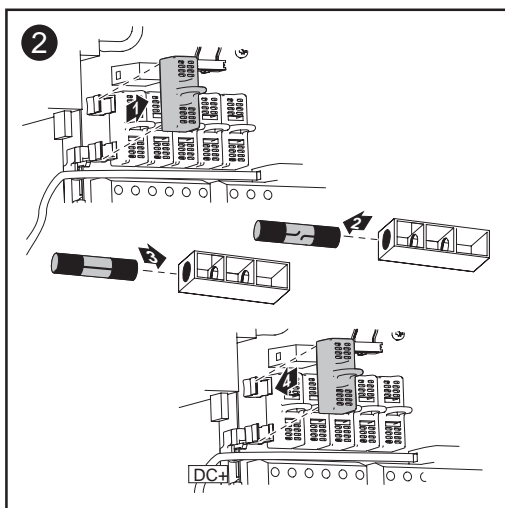

3 After replacing the fuse:
- Find out and correct the cause for the defective fuse

Closing Fronius IG Plus

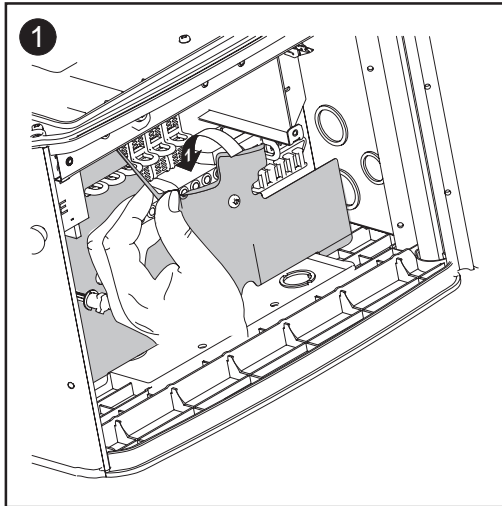

Return plastic dividers to their proper position

Important Make sure that the plastic dividers are underneath any data communication wires that are present.

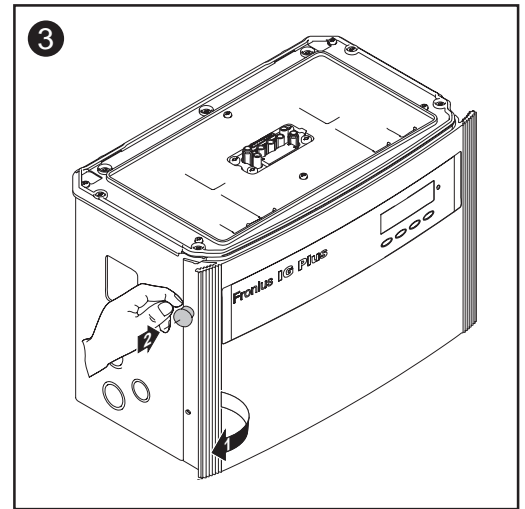
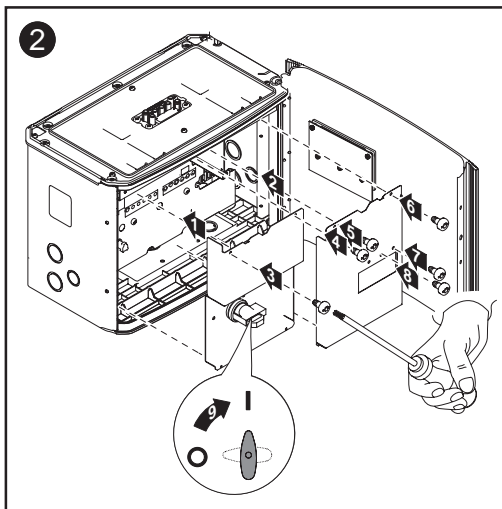

Replacing GFDI Fuse

Safety



WARNING! An electrical shock can be fatal. Danger from grid voltage and DC voltage from solar modules.

- The connection area should only be opened by a licensed electrician.
- Never work with live wires! Prior to all connection work, make sure that the AC and DC wires are not charged.
- The DC main switch is only used to switch off power to the power stage set. When the DC main switch is turned off, the connection area is still energized.

These servicing instructions are for use by qualified personnel only. To reduce the risk of electric shock, do not perform any servicing other than that specified in the operating instructions.



WARNING! An electrical shock can be fatal. Danger from residual voltage from capacitors.

You must wait until the capacitors have discharged. Discharge takes 5 minutes.



WARNING! An electric shock can be fatal. Normally grounded conductors may be ungrounded and energized when a ground fault is indicated. The ground fault has to be repaired before operation is resumed.

Preparation



NOTE

Disconnected AC and DC supply from the inverter.

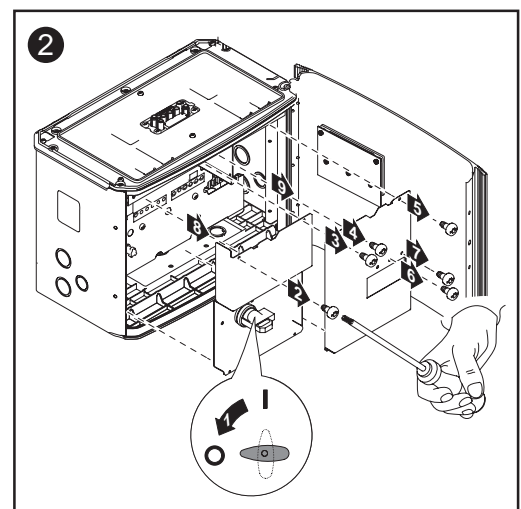
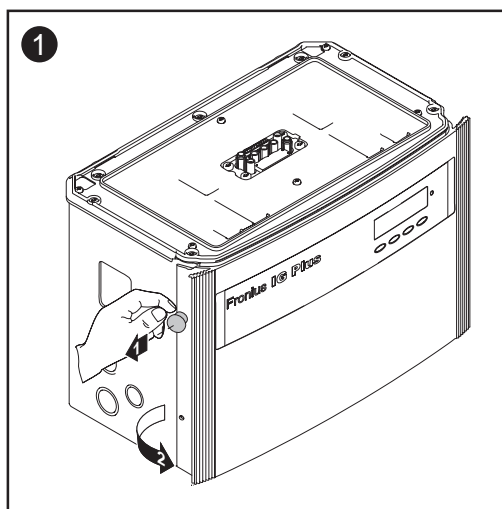

Preparation (continued)

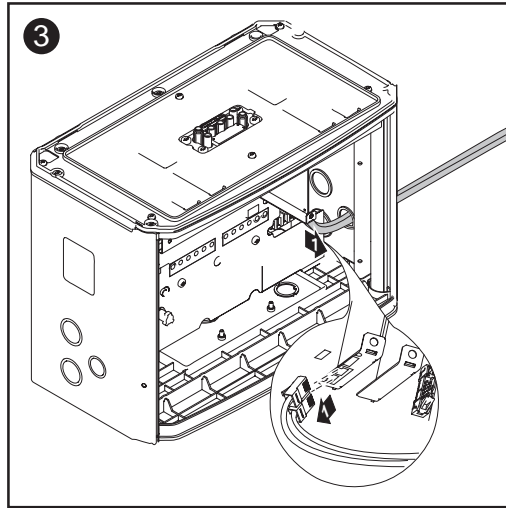

If present, disconnect data communication wire from the option cards.

Replacing GFDI Fuse



WARNING! An electrical shock can be fatal. Danger from DC voltage from solar modules.

- Never remove a fuse, while it is under load.
- Fuse covers are for installation purposes only. They offer no protection against contact.

1 Test the fuse holder at the terminal for continuity



NOTE Only use fuses that comply with the following data for the GFDI fuse:

Diameter 0.406 x 1.378 - 1.496 in. (10.3 x 35 - 38 mm), 1 A,
600 V DC

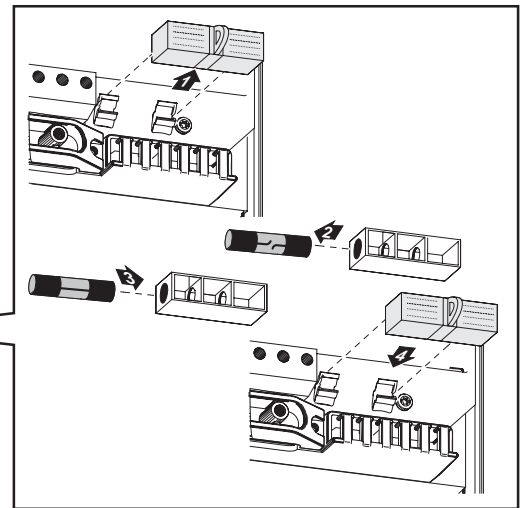
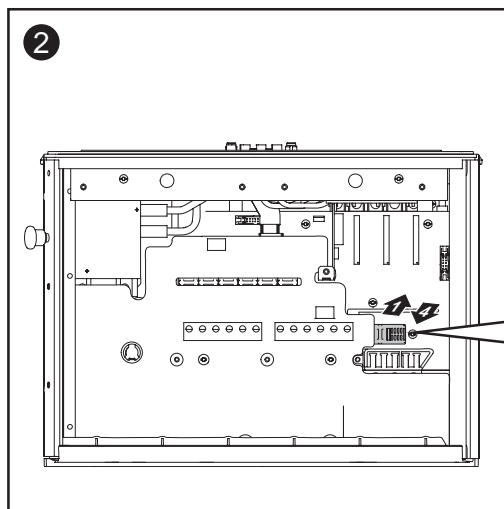

3 After replacing the fuse:
- Find out and correct the cause for the defective fuse

Closing Fronius IG Plus

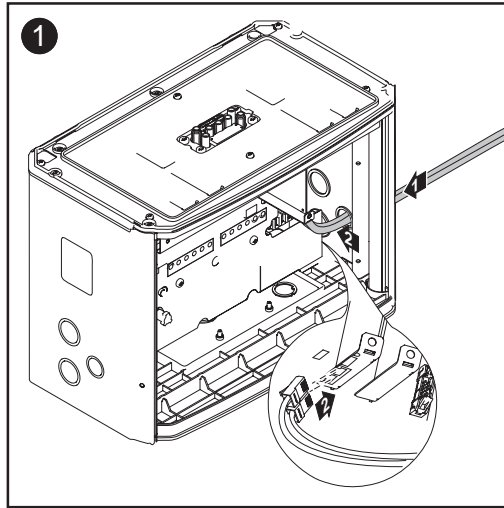

Connect available data communication wire to the option cards.

Important Make sure that the plastic dividers are underneath any data communication wires that are present.

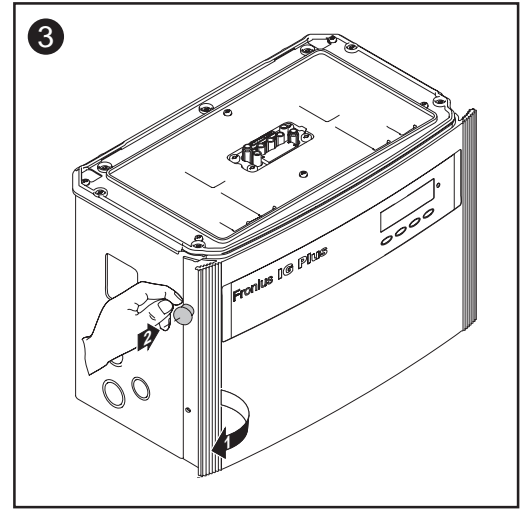
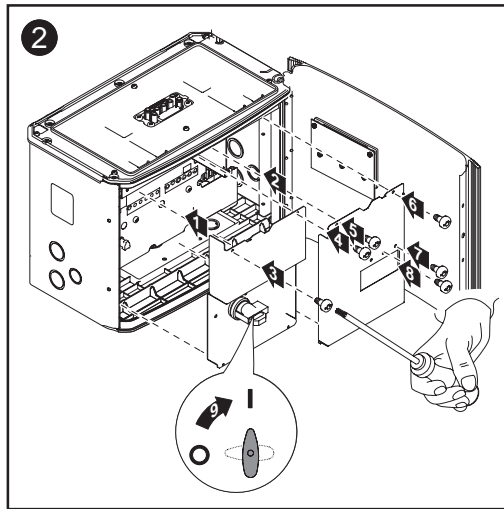

Appendix

Technical Data

Fronius IG Plus 3.0-1

Input data

Recommended PV power	2500 - 3450 Wp
MPPT-voltage range	230 - 500 V DC
Max. input voltage (at 1000 W/m ² / 14 °F in open circuit operation)	600 V DC
Nominal input voltage	390 V
Nominal input current	8.3 A
Maximum usable input current	14 A
Max. array short circuit current	18 A

Output data

Nominal output power (P_{nom})	3000 W	
P_{nom} at +122 °F (50 °C)	3000 W	
Maximum continuous output power	3000 W	
Nominal AC output voltage	208 V / 240 V / 277 V (-12 / +10 %)	
Operating AC voltage range default	at 208 V	183 - 229 V
	at 240 V	211 - 264 V
	at 277 V	244 - 305 V
Adjustment range for voltage	at 208 V	105 - 248 V
	at 240 V	120 - 287 V
	at 277 V	140 - 324 V
Voltage trip limit accuracy	1 % of nominal value	
Voltage clearing times	0.016 - 4.25 s	
Nominal output current	at 208 V	14.4 A AC
	at 240 V	12.5 A AC
	at 277 V	10.8 A AC
Number of phases	1	
Maximum output current	at 208 V	16.4 A
	at 240 V	14.2 A
	at 277 V	12.3 A
Maximum continuous utility backfeed current *	0 A	
Synchronization in-rush current *	0 A	
Maximum output fault current / duration	222 A / 47 µs	
Nominal output frequency	60 Hz	
Operating frequency range	59.3 - 60.5 Hz	
Adjustment range for frequency	57.0 - 60.48 Hz	

**Fronius IG
Plus 3.0-1**
(continued)

Frequency trip limit accuracy	0.05 Hz
Frequency clearing times	0.016 - 300 s
Total harmonic distortion	< 3 %
Power factor	1

* assured by electrical design of the inverter.

General data

Maximum efficiency	96.2 %
CEC efficiency	at 208 V 95.0 % at 240 V 95.5 % at 277 V 95.5 %
Consumption in standby (night)	< 1 W
Consumption during operation	8 W
Cooling	controlled forced ventilation
Protection type	NEMA 3R
Unit dimensions (w x h x d)	24.84 x 17.09 x 9.61 in. 631 x 434 x 244 mm
Inverter weight	31 lbs. 14 kg
Wiring compartment weight	24 lbs. 11 kg
Shipping dimensions (w x h x d)	31.02 x 20.28 x 14.02 in. 788 x 515 x 356 mm
Shipping weight	59 lbs. 27 kg
Admissible ambient temperature (with 95% rel. humidity)	-4 °F - +122 °F -20 °C - +50 °C
Admissible storage temperature (with 95% rel. humidity)	-4 °F - +140 °F -20 °C - +60 °C

Protection devices

Ground fault protection	internal GFDI (Ground Fault Detector/Interruptor)
Islanding protection	internal
DC reverse polarity protection	internal diode
Over temperature	output power derating / active cooling

Input data

Recommended PV power	3200 - 4400 Wp
MPPT-voltage range	230 - 500 V DC
Max. input voltage (at 1000 W/m ² / 14 °F in open circuit operation)	600 V DC
Nominal input voltage	390 V
Nominal input current	10.5 A
Maximum usable input current	17.8 A
Max. array short circuit current	22 A

Output data

Nominal output power (P _{nom})	3800 W
P _{nom} at +122 °F (50 °C)	3800 W
Maximum continuous output power	3800 W
Nominal AC output voltage	208 V / 240 V / 277 V (-12 / +10 %)
Operating AC voltage range default	at 208 V 183 - 229 V
	at 240 V 211 - 264 V
	at 277 V 244 - 305 V
Adjustment range for voltage	at 208 V 105 - 248 V
	at 240 V 120 - 287 V
	at 277 V 140 - 324 V
Voltage trip limit accuracy	1 % of nominal value
Voltage clearing times	0.016 - 4.25 s
Nominal output current	at 208 V 18.3 A AC
	at 240 V 15.8 A AC
	at 277 V 13.7 A AC
Number of phases	1
Maximum output current	at 208 V 18.5 A
	at 240 V 18.0 A
	at 277 V 15.6 A
Maximum continuous utility backfeed current *	0 A
Synchronization in-rush current *	0 A
Maximum output fault current / duration	222 A / 47 μs
Nominal output frequency	60 Hz
Operating frequency range	59.3 - 60.5 Hz
Adjustment range for frequency	57.0 - 60.48 Hz

**Fronius IG
Plus 3.8-1**
(continued)

Frequency trip limit accuracy	0.05 Hz
Frequency clearing times	0.016 - 300 s
Total harmonic distortion	< 3 %
Power factor	1

* assured by electrical design of the inverter.

General data

Maximum efficiency	96.2 %
CEC efficiency	at 208 V 95.0 % at 240 V 95.5 % at 277 V 95.5 %
Consumption in standby (night)	< 1 W
Consumption during operation	8 W
Cooling	controlled forced ventilation
Protection type	NEMA 3R
Unit dimensions (w x h x d)	48.07 x 17.09 x 9.61 in. 1221 x 434 x 244 mm
Inverter weight	82 lbs. 37 kg
Wiring compartment weight	26 lbs. 12 kg
Shipping dimensions (w x h x d)	42.72 x 20.28 x 14.02 in. + 17.72 x 20.28 x 14.02 in. 1085 x 515 x 356 mm + 450 x 515 x 356 mm
Shipping weight	114 lbs. 52 kg
Admissible ambient temperature (with 95% rel. humidity)	-4 °F - +122 °F -20 °C - +50 °C
Admissible storage temperature (with 95% rel. humidity)	-4 °F - +140 °F -20 °C - +60 °C

Protection devices

Ground fault protection	internal GFDI (Ground Fault Detector/Interruptor)
Islanding protection	internal
DC reverse polarity protection	internal diode
Over temperature	output power derating / active cooling

**Fronius IG
Plus 5.0-1**

Input data

Recommended PV power	4250 - 5750 Wp
MPPT-voltage range	230 - 500 V DC
Max. input voltage (at 1000 W/m ² / 14 °F in open circuit operation)	600 V DC
Nominal input voltage	390 V
Nominal input current	13.8 A
Maximum usable input current	23.4 A
Max. array short circuit current	29 A

Output data

Nominal output power (P _{nom})	5000 W
P _{nom} at +122 °F (50 °C)	5000 W
Maximum continuous output power	5000 W
Nominal AC output voltage	208 V / 240 V / 277 V (-12 / +10 %)
Operating AC voltage range default	at 208 V 183 - 229 V
	at 240 V 211 - 264 V
	at 277 V 244 - 305 V
Adjustment range for voltage	at 208 V 105 - 248 V
	at 240 V 121 - 287 V
	at 277 V 140 - 324 V
Voltage trip limit accuracy	1 % of nominal value
Voltage clearing times	0.016 - 4.25 s
Nominal output current	at 208 V 24.0 A AC
	at 240 V 20.8 A AC
	at 277 V 18.1 A AC
Number of phases	1
Maximum output current	at 208 V 27.3 A
	at 240 V 23.7 A
	at 277 V 20.5 A
Maximum continuous utility backfeed current *	0 A
Synchronization in-rush current *	0 A
Maximum output fault current / duration	273 A / 72 μs
Nominal output frequency	60 Hz
Operating frequency range	59.3 - 60.5 Hz
Adjustment range for frequency	57.0 - 60.48 Hz

**Fronius IG
Plus 5.0-1**
(continued)

Frequency trip limit accuracy	0.05 Hz
Frequency clearing times	0.016 - 300 s
Total harmonic distortion	< 3 %
Power factor	1

* assured by electrical design of the inverter.

General data

Maximum efficiency	96.2 %
CEC efficiency	at 208 V 95.5 % at 240 V 95.5 % at 277 V 96.0 %
Consumption in standby (night)	< 1 W
Consumption during operation	15 W
Cooling	controlled forced ventilation
Protection type	NEMA 3R
Unit dimensions (w x h x d)	36.46 x 17.09 x 9.61 in. 926 x 434 x 244 mm
Inverter weight	57 lbs. 4 kg
Wiring compartment weight	24 bs. 11 kg
Shipping dimensions (w x h x d)	42.72 x 20.28 x 14.02 in. 1085 x 515 x 356 mm
Shipping weight	90 lbs. 41 kg
Admissible ambient temperature (with 95% rel. humidity)	-4 °F - +122 °F -20 °C - +50 °C
Admissible storage temperature (with 95% rel. humidity)	-4 °F - +140 °F -20 °C - +60 °C

Protection devices

Ground fault protection	internal GFDI (Ground Fault Detector/Interruptor)
Islanding protection	internal
DC reverse polarity protection	internal diode
Over temperature	output power derating / active cooling

**Fronius IG
Plus 6.0-1**

Input data

Recommended PV power	5100 - 6900 Wp
MPPT-voltage range	230 - 500 V DC
Max. input voltage (at 1000 W/m ² / 14 °F in open circuit operation)	600 V DC
Nominal input voltage	390 V
Nominal input current	16.6 A
Maximum usable input current	28.1 A
Max. array short circuit current	35 A

Output data

Nominal output power (P _{nom})	6000 W	
P _{nom} at +122 °F (50 °C)	6000 W	
Maximum continuous output power	6000 W	
Nominal AC output voltage	208 V / 240 V / 277 V (-12 / +10 %)	
Operating AC voltage range default	at 208 V	183 - 229 V
	at 240 V	211 - 264 V
	at 277 V	244 - 305 V
Adjustment range for voltage	at 208 V	105 - 248 V
	at 240 V	121 - 287 V
	at 277 V	140 - 324 V
Voltage trip limit accuracy	1 % of nominal value	
Voltage clearing times	0.016 - 4.25 s	
Nominal output current	at 208 V	28.8 A AC
	at 240 V	25.0 A AC
	at 277 V	21.7 A AC
Number of phases	1	
Maximum output current	at 208 V	32.8 A
	at 240 V	28.4 A
	at 277 V	24.6 A
Maximum continuous utility backfeed current *	0 A	
Synchronization in-rush current *	0 A	
Maximum output fault current / duration	273 A / 72 μs	
Nominal output frequency	60 Hz	
Operating frequency range	59.3 - 60.5 Hz	
Adjustment range for frequency	57.0 - 60.48 Hz	

**Fronius IG
Plus 6.0-1**
(continued)

Frequency trip limit accuracy	0.05 Hz
Frequency clearing times	0.016 - 300 s
Total harmonic distortion	< 3 %
Power factor	1

* assured by electrical design of the inverter.

General data

Maximum efficiency	96.2 %
CEC efficiency	at 208 V 95.5 % at 240 V 96.0 % at 277 V 96.0 %
Consumption in standby (night)	< 1 W
Consumption during operation	15 W
Cooling	controlled forced ventilation
Protection type	NEMA 3R
Unit dimensions (w x h x d)	36.46 x 17.09 x 9.61 in. 926 x 434 x 244 mm
Inverter weight	57 lbs. 26 kg
Wiring compartment weight	26 lbs. 12 kg
Shipping dimensions (w x h x d)	42.72 x 20.28 x 14.02 in. 1085 x 515 x 356 mm
Shipping weight	90 lbs. 41 kg
Admissible ambient temperature (with 95% rel. humidity)	-4 °F - +122 °F -20 °C - +50 °C
Admissible storage temperature (with 95% rel. humidity)	-4 °F - +140 °F -20 °C - +60 °C

Protection devices

Ground fault protection	internal GFDI (Ground Fault Detector/Interruptor)
Islanding protection	internal
DC reverse polarity protection	internal diode
Over temperature	output power derating / active cooling

**Fronius IG
Plus 7.5-1**

Input data

Recommended PV power	6350 - 8600 Wp
MPPT-voltage range	230 - 500 V DC
Max. input voltage (at 1000 W/m ² / 14 °F in open circuit operation)	600 V DC
Nominal input voltage	390 V
Nominal input current	20.7 A
Maximum usable input current	35.1 A
Max. array short circuit current	44 A

Output data

Nominal output power (P _{nom})	7500 W	
P _{nom} at +122 °F (50 °C)	7500 W (6800 W at 208 V)	
Maximum continuous output power	7500 W	
Nominal AC output voltage	208 V / 240 V / 277 V (-12 / +10 %)	
Operating AC voltage range default	at 208 V	183 - 229 V
	at 240 V	211 - 264 V
	at 277 V	244 - 305 V
Adjustment range for voltage	at 208 V	105 - 248 V
	at 240 V	121 - 287 V
	at 277 V	140 - 324 V
Voltage trip limit accuracy	1 % of nominal value	
Voltage clearing times	0.016 - 4.25 s	
Nominal output current	at 208 V	36.1 A AC
	at 240 V	31.3 A AC
	at 277 V	27.1 A AC
Number of phases	1	
Maximum output current	at 208 V	37.0 A
	at 240 V	35.5 A
	at 277 V	30.7 A
Maximum continuous utility backfeed current *	0 A	
Synchronization in-rush current *	0 A	
Maximum output fault current / duration	273 A / 72 μs	
Nominal output frequency	60 Hz	
Operating frequency range	59.3 - 60.5 Hz	
Adjustment range for frequency	57.0 - 60.48 Hz	

**Fronius IG
Plus 7.5-1**
(continued)

Frequency trip limit accuracy	0.05 Hz
Frequency clearing times	0.016 - 300 s
Total harmonic distortion	< 3 %
Power factor	1

* assured by electrical design of the inverter.

General data

Maximum efficiency	96.2 %
CEC efficiency	at 208 V 95.0 % at 240 V 95.5 % at 277 V 96.0 %
Consumption in standby (night)	< 1 W
Consumption during operation	15 W
Cooling	controlled forced ventilation
Protection type	NEMA 3R
Unit dimensions (w x h x d)	36.46 x 17.09 x 9.61 in. 926 x 434 x 244 mm
Inverter weight	57 lbs. 26 kg
Wiring compartment weight	26 lbs. 12 kg
Shipping dimensions (w x h x d)	42.72 x 20.28 x 14.02 in. 1085 x 515 x 356 mm
Shipping weight	90 lbs. 41 kg
Admissible ambient temperature (with 95% rel. humidity)	-4 °F - +122 °F -20 °C - +50 °C
Admissible storage temperature (with 95% rel. humidity)	-4 °F - +140 °F -20 °C - +60 °C

Protection devices

Ground fault protection	internal GFDI (Ground Fault Detector/Interruptor)
Islanding protection	internal
DC reverse polarity protection	internal diode
Over temperature	output power derating / active cooling

**Fronius IG
Plus 10.0-1**

Input data

Recommended PV power	8500 - 11500 Wp
MPPT-voltage range	230 - 500 V DC
Max. input voltage (at 1000 W/m ² / 14 °F in open circuit operation)	600 V DC
Nominal input voltage	390 V
Nominal input current	27.6 A
Maximum usable input current	46.7 A
Max. array short circuit current	58 A

Output data

Nominal output power (P _{nom})	9995 W	
P _{nom} at +122 °F (50 °C)	9995 W	
Maximum continuous output power	9995 W	
Nominal AC output voltage	208 V / 240 V / 277 V (-12 / +10 %)	
Operating AC voltage range default	at 208 V	183 - 229 V
	at 240 V	211 - 264 V
	at 277 V	244 - 305 V
Adjustment range for voltage	at 208 V	105 - 248 V
	at 240 V	121 - 287 V
	at 277 V	140 - 324 V
Voltage trip limit accuracy	1 % of nominal value	
Voltage clearing times	0.016 - 4.25 s	
Nominal output current	at 208 V	48.1 A AC
	at 240 V	41.7 A AC
	at 277 V	36.1 A AC
Number of phases	1	
Maximum output current	at 208 V	54.6 A
	at 240 V	47.4 A
	at 277 V	40.9 A
Maximum continuous utility backfeed current *	0 A	
Synchronization in-rush current *	0 A	
Maximum output fault current / duration	586 A / 104 μs	
Nominal output frequency	60 Hz	
Operating frequency range	59.3 - 60.5 Hz	
Adjustment range for frequency	57.0 - 60.48 Hz	

**Fronius IG
Plus 10.0-1**
(continued)

Frequency trip limit accuracy	0.05 Hz
Frequency clearing times	0.016 - 300 s
Total harmonic distortion	< 3 %
Power factor	1

* assured by electrical design of the inverter.

General data

Maximum efficiency	96.2 %
CEC efficiency	at 208 V 95.0 % at 240 V 95.5 % at 277 V 96.0 %
Consumption in standby (night)	< 1 W
Consumption during operation	22 W
Cooling	controlled forced ventilation
Protection type	NEMA 3R
Unit dimensions (w x h x d)	48.07 x 17.09 x 9.61 in. 1221 x 434 x 244 mm
Inverter weight	82 lbs. 37 kg
Wiring compartment weight	26 lbs. 12 kg
Shipping dimensions (w x h x d)	42.72 x 20.28 x 14.02 in. + 17.72 x 20.28 x 14.02 in. 1085 x 515 x 356 mm + 450 x 515 x 356 mm
Shipping weight	114 lbs. 52 kg
Admissible ambient temperature (with 95% rel. humidity)	-4 °F - +122 °F -20 °C - +50 °C
Admissible storage temperature (with 95% rel. humidity)	-4 °F - +140 °F -20 °C - +60 °C

Protection devices

Ground fault protection	internal GFDI (Ground Fault Detector/Interruptor)
Islanding protection	internal
DC reverse polarity protection	internal diode
Over temperature	output power derating / active cooling

**Fronius IG
Plus 11.4-1**

Input data

Recommended PV power	9700 - 13100 Wp
MPPT-voltage range	230 - 500 V DC
Max. input voltage (at 1000 W/m ² / 14 °F in open circuit operation)	600 V DC
Nominal input voltage	390 V
Nominal input current	31.4 A
Maximum usable input current	53.3 A
Max. array short circuit current	67 A

Output data

Nominal output power (P _{nom})	11400 W
P _{nom} at +122 °F (50 °C)	11400 W (10800 W at 208 V)
Maximum continuous output power	11400 W
Nominal AC output voltage	208 V / 240 V / 277 V
Operating AC voltage range default	at 208 V 183 - 229 V at 240 V 211 - 264 V at 277 V 244 - 305 V
Adjustment range for voltage	at 208 V 105 - 248 V at 240 V 121 - 287 V at 277 V 140 - 324 V
Voltage trip limit accuracy	1 % of nominal value
Voltage clearing times	0.016 - 4.25 s
Nominal output current	at 208 V 54.8 A AC at 240 V 47.5 A AC at 277 V 41.2 A AC
Number of phases	1
Maximum output current	at 208 V 55.5 A at 240 V 54.0 A at 277 V 46.7 A
Maximum continuous utility backfeed current *	0 A
Synchronization in-rush current *	0 A
Maximum output fault current / duration	586 A / 104 μs
Nominal output frequency	60 Hz
Operating frequency range	59.3 - 60.5 Hz
Adjustment range for frequency	57.0 - 60.48 Hz

**Fronius IG
Plus 11.4-1**
(continued)

Frequency trip limit accuracy	0.05 Hz
Frequency clearing times	0.016 -300 s
Total harmonic distortion	< 3 %
Power factor	1

* assured by electrical design of the inverter.

General data

Maximum efficiency	96.2 %
CEC efficiency	at 208 V 95.5 % at 240 V 96.0 % at 277 V 96.0 %
Consumption in standby (night)	< 1 W
Consumption during operation	22 W
Cooling	controlled forced ventilation
Protection type	NEMA 3R
Unit dimensions (w x h x d)	48.07 x 17.09 x 9.61 in. 1221 x 434 x 244 mm
Inverter weight	82 lbs. 37 kg
Wiring compartment weight	26 lbs. 12 kg
Shipping dimensions (w x h x d)	42.72 x 20.28 x 14.02 in. + 17.72 x 20.28 x 14.02 in. 1085 x 515 x 356 mm + 450 x 515 x 356 mm
Shipping weight	114 lbs. 52 kg
Admissible ambient temperature (with 95% rel. humidity)	-4 °F - +122 °F -20 °C - +50 °C
Admissible storage temperature (with 95% rel. humidity)	-4 °F - +140 °F -20 °C - +60 °C

Protection devices

Ground fault protection	internal GFDI (Ground Fault Detector/Interruptor)
Islanding protection	internal
DC reverse polarity protection	internal diode
Over temperature	output power derating / active cooling

**Fronius IG
Plus 11.4-3**

Input data

Recommended PV power	9700 - 13100 Wp
MPPT-voltage range	230 - 500 V DC
Max. input voltage (at 1000 W/m ² / 14 °F in open circuit operation)	600 V DC
Nominal input voltage	390 V
Nominal input current	31.4 A
Maximum usable input current	53.3 A
Max. array short circuit current	67 A

Output data

Nominal output power (P _{nom})	11400 W
P _{nom} at +122 °F (50 °C)	11400 W (10800 W at 208 V)
Maximum continuous output power	11400 W
Nominal AC output voltage	208 V / 240 V
Operating AC voltage range default	at 208 V 183 - 229 V at 240 V 211 - 264 V
Adjustment range for voltage	at 208 V 105 - 248 V at 240 V 121 - 287 V
Voltage trip limit accuracy	1 % of nominal value
Voltage clearing times	0.016 - 4.25 s
Nominal output current	at 208 V 31.6 A AC at 240 V 27.4 A AC
Number of phases	3
Maximum output current	at 208 V 32.0 A at 240 V 31.2 A
Maximum continuous utility backfeed current *	0 A
Synchronization in-rush current *	0 A
Maximum output fault current / duration	476 A / 623 μs
Nominal output frequency	60 Hz
Operating frequency range	59.3 - 60.5 Hz
Adjustment range for frequency	57.0 - 60.48 Hz

**Fronius IG
Plus 11.4-3**
(continued)

Frequency trip limit accuracy	0.05 Hz
Frequency clearing times	0.016 - 300 s
Total harmonic distortion	< 3 %
Power factor	1

* assured by electrical design of the inverter.

General data

Maximum efficiency	96.2 %
CEC efficiency	at 208 V 95.0 % at 240 V 95.5 %
Consumption in standby (night)	< 1 W
Consumption during operation	22 W
Cooling	controlled forced ventilation
Protection type	NEMA 3R
Unit dimensions (w x h x d)	48.07 x 17.09 x 9.61 in. 1221 x 434 x 244 mm
Inverter weight	82 lbs. 37 kg
Wiring compartment weight	26 lbs. 12 kg
Shipping dimensions (w x h x d)	42.72 x 20.28 x 14.02 in. + 17.72 x 20.28 x 14.02 in. 1085 x 515 x 356 mm + 450 x 515 x 356 mm
Shipping weight	114 lbs. 52 kg
Admissible ambient temperature (with 95% rel. humidity)	-4 °F - +122 °F -20 °C - +50 °C
Admissible storage temperature (with 95% rel. humidity)	-4 °F - +140 °F -20 °C - +60 °C

Protection devices

Ground fault protection	internal GFDI (Ground Fault Detector/Interruptor)
Islanding protection	internal
DC reverse polarity protection	internal diode
Over temperature	output power derating / active cooling

**Fronius IG
Plus 12.0-3**

Input data

Recommended PV power	10200 - 13800 Wp
MPPT-voltage range	230 - 500 V DC
Max. input voltage (at 1000 W/m ² / 14 °F in open circuit operation)	600 V DC
Nominal input voltage	390 V
Nominal input current	33.1 A
Maximum usable input current	56.1 A
Max. array short circuit current	70 A

Output data

Nominal output power (P _{nom})	12000 W
P _{nom} at +122 °F (50 °C)	12000 W
Maximum continuous output power	12000 W
Nominal AC output voltage	277 V
Operating AC voltage range default	at 277 V 244 - 305 V
Adjustment range for voltage	at 277 V 140 - 324 V
Voltage trip limit accuracy	1 % of nominal value
Voltage clearing times	0.016 - 4.25 s
Nominal output current	at 277 V 14.4 A
Number of phases	3
Maximum output current	at 277 V 16.4 A
Maximum continuous utility backfeed current *	0 A
Synchronization in-rush current *	0 A
Maximum output fault current / duration	777 A / 163 μs
Nominal output frequency	60 Hz
Operating frequency range	59.3 - 60.5 Hz
Adjustment range for frequency	57.0 - 60.48 Hz

**Fronius IG
Plus 12.0-3**
(continued)

Frequency trip limit accuracy	0.05 Hz
Frequency clearing times	0.016 - 300 s
Total harmonic distortion	< 3 %
Power factor	1

* assured by electrical design of the inverter.

General data

Maximum efficiency	96.2 %
CEC efficiency	at 277 V 96.0 %
Consumption in standby (night)	< 1 W
Consumption during operation	22 W
Cooling	controlled forced ventilation
Protection type	NEMA 3R
Unit dimensions (w x h x d)	48.07 x 17.09 x 9.61 in. 1221 x 434 x 244 mm
Inverter weight	82 lbs. 37 kg
Wiring compartment weight	26 lbs. 12 kg
Shipping dimensions (w x h x d)	42.72 x 20.28 x 14.02 in. + 17.72 x 20.28 x 14.02 in. 1085 x 515 x 356 mm + 450 x 515 x 356 mm
Shipping weight	114 lbs. 52 kg
Admissible ambient temperature (with 95% rel. humidity)	-4 °F - +122 °F -20 °C - +50 °C
Admissible storage temperature (with 95% rel. humidity)	-4 °F - +140 °F -20 °C - +60 °C

Protection devices

Ground fault protection	internal GFDI (Ground Fault Detector/Interruptor)
Islanding protection	internal
DC reverse polarity protection	internal diode
Over temperature	output power derating / active cooling

Field adjustable trip points

Field adjustable trip points	208 V	240 V	277 V
Nominal AC output voltage, Line-to-Line, [V]	208	240	277
Operating AC voltage range default, Line-to-Line, [V]	183-229	211-264	-
Adjustment range for voltage, Line-to-Line, [V]	105-248	121-287	-
Voltage trip limit accuracy, Line-to-Line [% of nominal value]	1	1	-
Operating AC voltage range, Line-to-Neutral, [V]	106-132	106-132	244-305
Adjustment range for voltage, Line-to-Neutral, [V]	61-143	61-143	138-324
Adjustment range for voltage clearing time [s]	0.016-4.25	0.016-4.25	0.016-4.25
Voltage trip limit accuracy, Line-to-Neutral [% of nominal value]	1	1	1
Nominal output frequency [Hz]	60	60	60
Operating frequency range [Hz]	59.3-60.5	59.3-60.5	59.3-60.5
Adjustment range for frequency [Hz]	57.0-60.48	57.0-60.48	57.0-60.48
Adjustment range for frequency clearing time [s]	0.016-300	0.016-300	0.016-300
Frequency trip limit accuracy [ms]	16.66 ⁽¹⁾	16.66 ⁽¹⁾	16.66 ⁽¹⁾
Detection time [ms]	25 ⁽²⁾	25 ⁽²⁾	25 ⁽²⁾
Reconnect time default [s]	300	300	300
Adjustment range for reconnect time [s]	5-900	5-900	5-900

⁽¹⁾ 16.66 ms are equivalent to 1 cycle

⁽²⁾ 25 ms are equivalent to 1.5 cycles

Relevant Standards and Directives

- Relevant Standards and Directives**
- UL 1741-2005
 - IEEE 1547-2003
 - IEEE 1547.1
 - ANSI/IEEE C62.41
 - FCC Part 15 A & B
 - NEC Article 690
 - C22. 2 No. 107.1-01 (September 2001)

Grid Failure The standard measurement and safety procedures integrated into the Fronius IG Plus ensure that the power feed is immediately interrupted in the event of a grid failure (shut-off by the utility or damage to lines).

Warranty and Disposal

FRONIUS USA limited 10- Year Warranty

At Fronius, we have been designing and manufacturing high quality power electronics equipment for over 60 years. And all our production facilities are ISO 9001 certified.

You will probably not encounter any service-related issues with your Fronius IG Plus Solar Inverter. However, in the unlikely event that within Ten (10) years from the original purchase you discover a problem caused by defects in either workmanship or materials, we will see that it is either repaired or replaced. Repair or replacement depends on Fronius' evaluation of the issue and what we decide makes the most sense according to the situation. The warranty is based on the inverter's serial number, allowing the warranty to be transferred to another owner if the Fronius IG Plus Solar Inverter remains installed in the original installation location. Because the warranty is tied to the serial number, there is no paperwork to transfer the warranty to a new owner.

The Fronius IG Plus Solar Inverters are designed to withstand normal operating conditions and typical wear and tear when the Fronius IG Plus Solar Inverter is used for its original intent, in compliance with the Fronius IG Plus Installation and Operational Manual(s) supplied with the original equipment. This warranty does not cover damages by improper installation or operation, misuse, abuse, manipulation, alterations or repair attempts, accidents, fire, floods, acts of God, and incidental or consequential damage caused by defects with other components of the solar system. This warranty does not extend beyond the original cost of the Fronius IG Plus Solar Inverter.

Policy and procedure for warranty re- turns and repairs

To obtain service you must follow this policy and procedure for warranty returns and repairs:

- All returned Fronius IG Plus Solar Inverters require a Returned Merchandise Authorization Number (RMA)
- A request for a RMA number requires the following information:
 - Model Number of the Fronius IG Plus Solar Inverter
 - Serial Number of the Fronius IG Plus Inverter
 - Description of the problem
 - Shipping address for the repaired or replaced equipment

- All Fronius IG Plus Solar Inverters authorized for return by FRONIUS USA must be returned in their original shipping container or packaging providing equal protection
- Shipping costs to FRONIUS USA and back to the purchaser of repaired or replacement Fronius IG Plus Solar Inverters is the responsibility of FRONIUS USA

Policy and procedure for warranty returns and repairs

(continued)

- The warranty period of any repaired or replacement inverter is 12 months after shipment from FRONIUS USA or the original warranty period which ever is later
- Labor costs related to uninstalling the defective equipment and re-installing the repaired or replacement equipment are not covered under the warranty.

Some states do not allow the exclusion or limitation of incidental or consequential damages. This warranty gives you specific legal rights, and you may also have other rights, which vary from state to state.

FRONIUS USA LLC General Terms and Conditions apply.

Contact your local dealer or FRONIUS Service Partner for immediate handling of warranty issues. For service assistance to resolve a Fronius IG Plus solar inverter problem, or for product information please contact:

FRONIUS USA LLC - Solar Electronics Division
10421 Citation Drive, Suite 1100, Brighton, MI 48116
E-Mail: pv-us@fronius.com
<http://www.fronius-usa.com>

Disposal of obsolete equipment - Recycling

Should your inverter be replaced at some future date, Fronius will accept the obsolete equipment back and provide for its proper recycling.



Certificate of Compliance

Certificate: 2065918 **Master Contract:** 203213
Project: 2097497 **Date Issued:** 2008/11/14
Issued to: **Fronius International GmbH**
Guenter Fronius Strasse 1
Wels-Thalheim, 4600
Austria
Attention: Mr. Josef Feichtinger

The products listed below are eligible to bear the CSA Mark shown with adjacent indicator 'US'



Issued by: Rob Hempstock, ASCT.

Authorized by: Lindsay Clark, Product Group Manager

PRODUCTS

CLASS 5311 89 - POWER SUPPLIES - Distributed Generation - Power Systems Equipment
- Certified to U.S. Standards

Utility Interactive Inverter, Models Fronius IG Plus 3.0-1 UNI, Fronius IG Plus 3.8-1 UNI, SunPower SPR-3300f, SunPower SPR-4000f, Fronius IG Plus 5.0-1 UNI, Fronius IG Plus 6.0-1 UNI, Fronius IG Plus 7.5-1 UNI, SunPower SPR-6500f, SunPower SPR-8000f, Fronius IG Plus 10.0-1 UNI, Fronius IG Plus 11.4-1 UNI, and Fronius IG Plus 12.0-3 WYE277, Fronius IG Plus 11.4-3 Delta and SunPower SPR-12000f, permanently connected.

For details related to rating, size, configuration, etc., reference should be made to the CSA Certification Record or the Descriptive Report or Attachment 1.

The 'US' indicator adjacent to the CSA Mark signifies that the product has been evaluated to the applicable ANSI/UL Standards, for use in the U.S.. This 'US' indicator includes products eligible to bear the 'NRTL' indicator. NRTL, i.e. National Recognized Testing Laboratory, is a designation granted by the U.S. Occupational Safety and Health Administration (OSHA) to laboratories which have been recognized to perform certification to U.S. Standards.



Certificate: 2065918

Master Contract: 203213

Project: 2097497

Date Issued: 2008/11/14

APPLICABLE REQUIREMENTS

*UL Std. No. 1741-First Edition - Inverter, Converters, Controllers and Interconnection System Equipment for Use With Distributed Energy Resources (Including revisions through and including November 7, 2005)

*Note: Conformity to UL Std. No. 1741-First Edition (Including revisions through and including November 7, 2005) includes compliance with applicable requirements of IEEE 1547 and IEEE 1547.1

Fronius Worldwide - www.fronius.com/addresses

A **Fronius International GmbH**
4600 Wels-Thalheim, Günter-Fronius-Straße 1, Austria
E-Mail: pv@fronius.com
<http://www.fronius.com>

USA **Fronius USA LLC Solar Electronics Division**
10421 Citation Drive, Suite 1100, Brighton, MI 48116
E-Mail: pv-us@fronius.com
<http://www.fronius-usa.com>

Under <http://www.fronius.com/addresses> you will find all addresses of our sales branches and partner firms!